

**Technical note**

**ANALYSIS OF ENERGY CONSUMPTION AND POSSIBILITIES OF  
THERMAL-MODERNIZATION IN RESIDENTIAL BUILDINGS IN  
POLAND CASE STUDY: THE TOWN OF ZIELONA GÓRA**

A. ALSABRY\*

University of Zielona Góra  
Faculty of Civil Engineering, Architecture and Environmental Engineering  
str. Licealna 9, 65-417 Zielona Góra, POLAND  
E-mail: aalsabry@uz.zgora.pl

P. TRUSZKIEWICZ

University of Zielona Góra  
Faculty of Law and Administration  
str. Licealna 9, 65-417 Zielona Góra, POLAND

K. SZYMAŃSKI

ul. Macedońska 27/9, 51-113 Wrocław, POLAND  
E-mail: K.Szymanski@wp.eu

K. ŁASKAWIEC

ul. Jasna 24, 66-016 Czerwieńsk, POLAND  
E-mail: laskawiec.kamil@gmail.com

Ł. ROJEK

ul. Boryny 7, 66-300 Międzyrzecz, POLAND  
E-mail: lukaszrojo@poczta.onet.pl

The article presents an analysis of buildings belonging the Department of Public Utilities and Housing in Zielona Góra. The research was based on a set of questions for building operators. The questionnaires consisted of 30 questions concerning general and detailed information about the buildings. In order to clearly present the results, this article includes data only about residential and residential-commercial buildings. Forty building built in different periods were selected for analysis.

**Key words:** energy consumption, thermal-upgrading, energy effectiveness.

## 1. Introduction

Buildings are responsible for at least 40% of energy consumption in most countries. The absolute figure is rising fast, as construction booms, especially in countries such as China and India. It is essential to act now, because buildings can make a major contribution to tackling climate change and energy use. Over 45% of the energy use was from heating [1], [2] and [11].

However, the proportional energy use varies greatly, depending on the location and building parameters. The services demanded of buildings — lighting, warmth in the winter, cooling in the summer, water heating, electronic entertainment, computing, refrigeration, and cooking — require significant energy use, about 40 quadrillion Btu (quads) per year.

---

\* To whom correspondence should be addressed

Energy consumption in buildings has been growing in aggregate over time. Today, the nation's 114 million households and more than 4.7 billion commercial buildings consume more energy than the transportation or industry sectors, accounting for nearly 40 percent of total U.S. energy use. The total utility bill for energy used by U.S. buildings topped \$369 billion in 2005. This energy use is driven by [3]:

- Population, which drives the number of homes, schools, and other community buildings.
- Economic growth (real GDP), which is a major driver of new floorspace in offices and retail buildings.
- Building size (the amount of commercial floorspace and the size of homes) .
- Service demands (lighting and space conditioning, electronics, process loads).
- Real energy prices.
- The efficiency with which energy service demands are met.

One of the major determinants of total residential energy use is the number of households. The number of U.S. households rose nearly 40 percent (80 million to 113 million) from 1980 to 2005, despite three periods of economic recession.

Households and housing are, in turn, driven by population growth. Overall, U.S. population rose from about 228 million in 1980 to nearly 300 million in 2005.

This growth about 30 percent is slower than the growth in households; household size (persons per household) decreased by 7 percent over the same period (Fig.1).

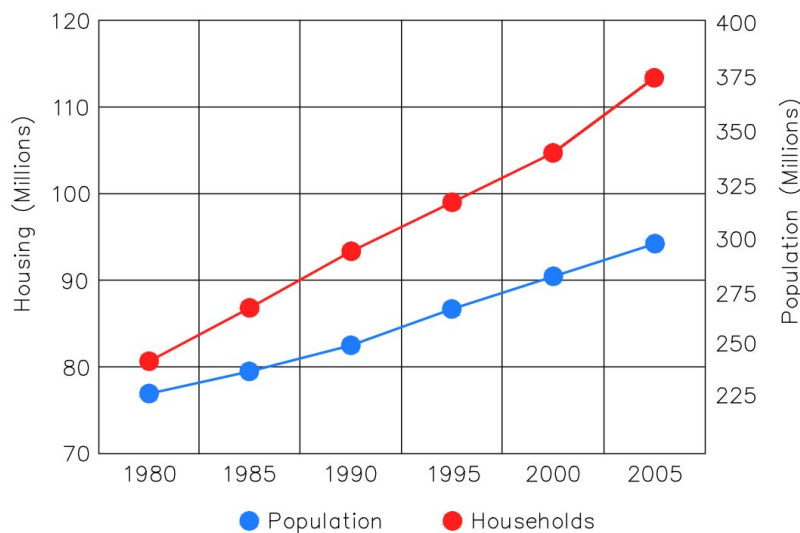

Fig.1. Growth in housing units [3]

In order to reduce the consumption of energy in engineering objects and achieve energy effectiveness, it is absolutely necessary to carry out thermal modernization in these buildings such as thermal insulation, the replacement of window frames and doors, modernization of lighting as well as installing smart energy-effective lighting systems, especially in public buildings.

As part of the national plan for the reduction of energy consumption in the construction sector the Polish government has undertaken measures described in such acts as:

- the Directive of the Minister of Transport, Construction and Maritime Economy of 5 July 2013 changing the technical requirements which buildings and their location should meet,
- the Directive of the Minister of Infrastructure and Development of 27 February 2015 on the methodology for determining the energy characteristics of buildings or their parts and certificates of energy characteristics, as well as
- the Directive of the Minister of Infrastructure and Development of 3 September 2015 changing the directive on the details and form of the energy audit and parts of the renovation audit, examples of audit forms, and the algorithm for the profitability assessment of thermal-modernization. The data presented in

this article result from analyses of the characteristics of buildings built in Zielona Góra in different years. The final results are part of the research project: “*Analysis of the social and economic results of increasing energy effectiveness in building construction*” carried out as part of the strategic research project “*Integrated system for reducing energy consumption in buildings*”.

The buildings were analysed in terms of: their design, construction technology, function, usable surface area, airspace, ventilation, energy consumption for heating, hot water, electrical energy, water, wastes, etc. The possibilities of thermal modernization in these objects were also analysed, including the thermal modernization activities that had already been carried out and those that were in plans. The abovementioned data were collected through surveys among the administrators of the buildings subjected to research.

The goals of the reviews included the stocktaking of technical items in selected settlement areas, including typical buildings. Data from the reviews were also used to estimate the energy effectiveness quality in the buildings and the amount and structure of potential for improving energy effectiveness, type of infrastructure for architectural-urban models in terms of potential improvement of energy effectiveness.

The research was carried out mainly in buildings belonging to the Office for Municipal and Housing Estate Management in Zielona Góra. The research was based on questionnaires for building administrators. They consisted of 30 questions open and closed. Most of them had a number of subsections. The questions were divided into two groups: general information about the building and detailed information. The general questions concerned:

the year of completion,  
location in terms of cardinal directions,  
function, type of building.

The detailed questions concerned the usable surface area, building airspace, type of external walls, and first of all heating systems, hot water systems and in particular energy consumption. The respondents were also asked about fees for energy units and planned thermal-modernization investments.

## 2. Characteristics of the buildings subjected to analysis

Figure 2 below presents the heat demand ratio depending on the year of completion and the energy classification of buildings according to the Association for Balanced Development

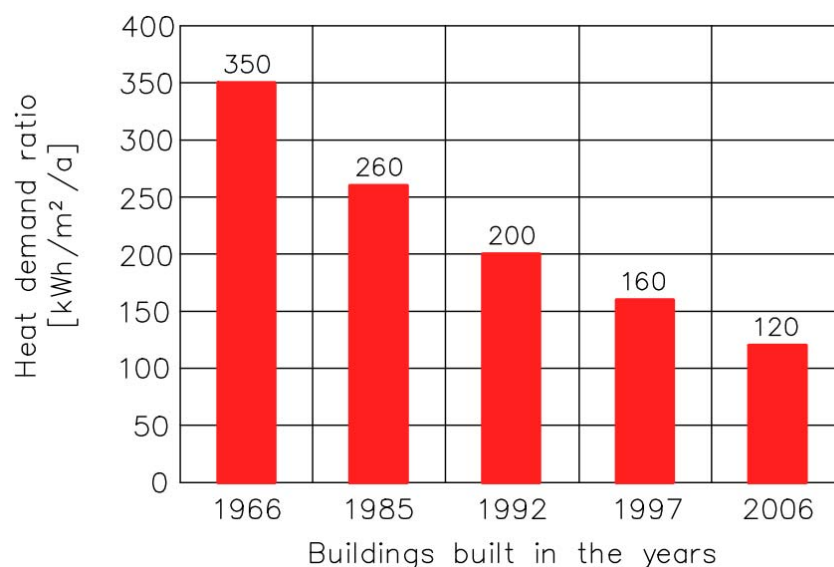

Fig.2. The classification of buildings [10].

The group of selected buildings consisted mainly of buildings built with traditional technology and ones serving different purposes, i.e., residential buildings, residential-service buildings, service buildings, industrial buildings, etc.

In order to clearly present the results, this article includes only data for dwelling buildings and dwelling-service buildings where only the ground floor is used for service purposes, and the other floors are used as dwellings. Several tens of buildings built at different times were selected for analysis (Fig.3).

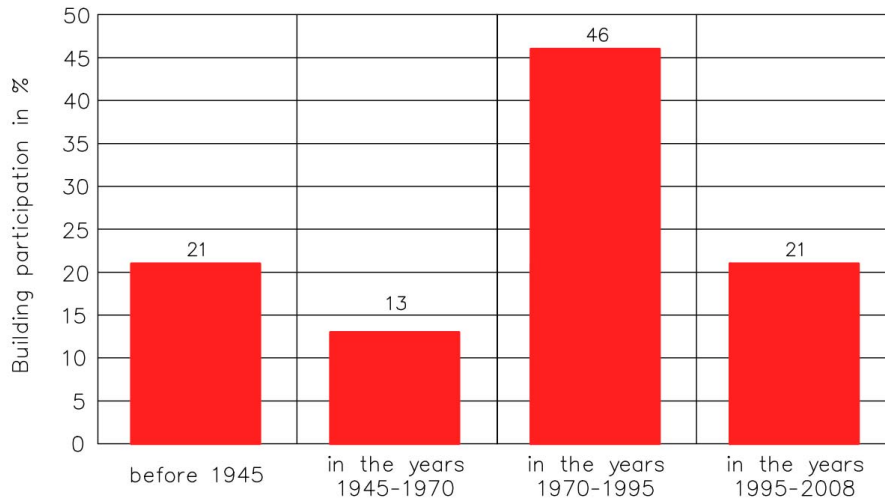

Fig.3. Percentage of buildings built in the years.

The selection of time spans is presented in Fig.3. Over 20% of the buildings were built before 1946. The other 13% of the buildings were built in the years 1945-1970, nearly half, i.e., 46% of the buildings analysed were built in the years 1970-1995, and 21% in the years 1995-2008.

Technical analysis began with the heated airspace of the buildings and the sum of the external walls surrounding the heated airspace, i.e., the sum of the surface of all walls, the ceiling (roof) and the floor (the ceiling above the unheated basement). The results are presented in the diagram in Fig.4.

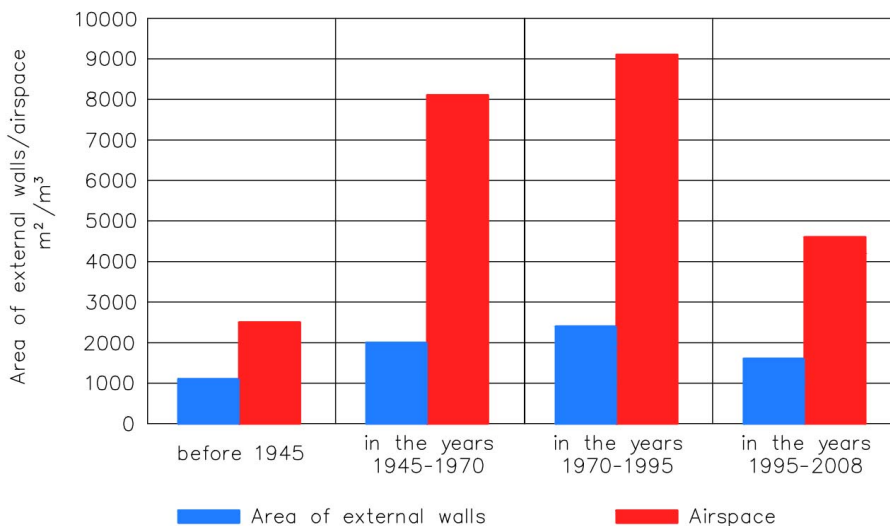

Fig.4. Area of external walls in relation to airspace in the buildings analysed.

The average heated airspace of the buildings built in the years 1945÷1995 is between 8000 and 9000 m<sup>2</sup> and they are usually high, multi-floor buildings. The heated airspace of the buildings built in the years 1996÷2008 is nearly twice smaller, i.e., about 5000 m<sup>2</sup>. The buildings built before 1945 have the smallest heated airspace, i.e., 2500 m<sup>2</sup>. The average area of walls surrounding heated airspace in the buildings built in the years 1945-1995 is 2000 m<sup>2</sup>. The buildings built in the years 1996-2008 have a smaller area, i.e., about 1500 m<sup>2</sup>. The buildings built before 1945 have the smallest area of external walls, i.e., 1000 m<sup>2</sup>. The heated airspace of buildings and the area of external walls surrounding it are extremely important factors when buildings are analysed in terms of their energy efficiency. However, when these data are analysed separately, we do not learn anything about the characteristics of a building in terms of energy consumption. The aspect ratio of a building is analysed, i.e., A/V [1/m]. It determines the compactness of a building. The surface A [m<sup>2</sup>] is not the usable surface of a building but the surface of the external walls surrounding heated airspace, i.e., it is for example the sum of the surface of the roof, the external walls, including the doors and windows, and the floors [7]. Then, this surface is divided into the heated airspace of a building. The best forms are those with the smallest area of external walls in relation to heated airspace. The sphere is a perfect form. Since spheres are not usually used in building construction, the best form in terms of compactness is the cube. This means that energy enclosed in it has the smallest area to “escape” through. In order to explain this problem in more detail, Fig.5 shows the influence of the form of a building on heat loss, assuming that 100% takes place in a building which is a cube [4].

The greater the value of this parameter, the less energy-efficient the building.

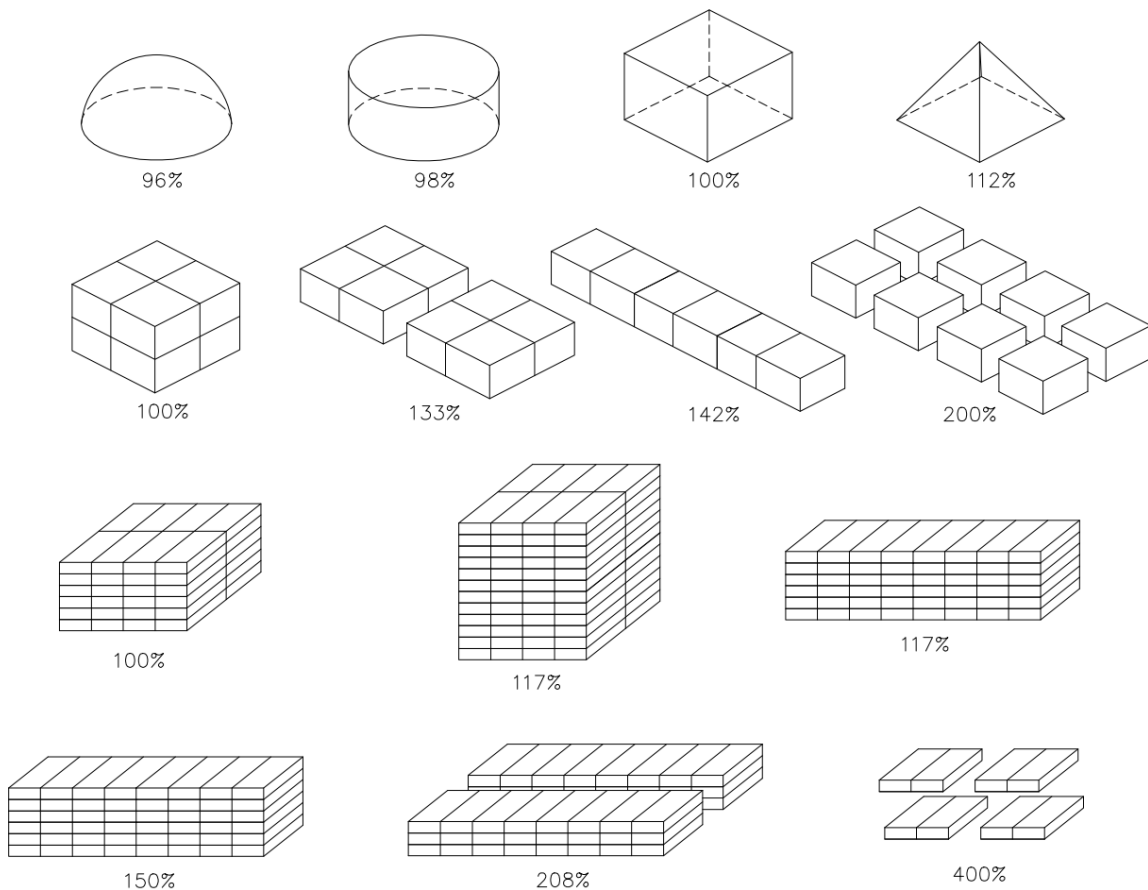

Fig.5. Heat loss depending on the form of a building in relation to the cube [5] and [6].

The buildings were analysed in terms of their aspect ratio A/V. It can be seen that in the years 1945-1995 more compact buildings were built, i.e. with a better aspect ratio – between about 0.30 and 0.35 [1/m].

Later the aspect ratio of buildings was on average about  $0.58 [1/m]$ . It was similar before 1945, when the average aspect ratio of the buildings analysed was about  $0.54 [1/m]$ . Attention should also be paid to the number of floors in buildings. The buildings built in the years 1945-1970 that were analysed had on average 4 floors, whereas those built in the years 1970-1995 had on average 7 floors. Hence such a big difference in the aspect ratio. The number of floors in the analysed group of buildings built before 1945 was similar to the number of floors in buildings built at present, i.e., about 3.

However, buildings built in the years 1945-1995 had the best forms in terms of compactness, see Fig.6.

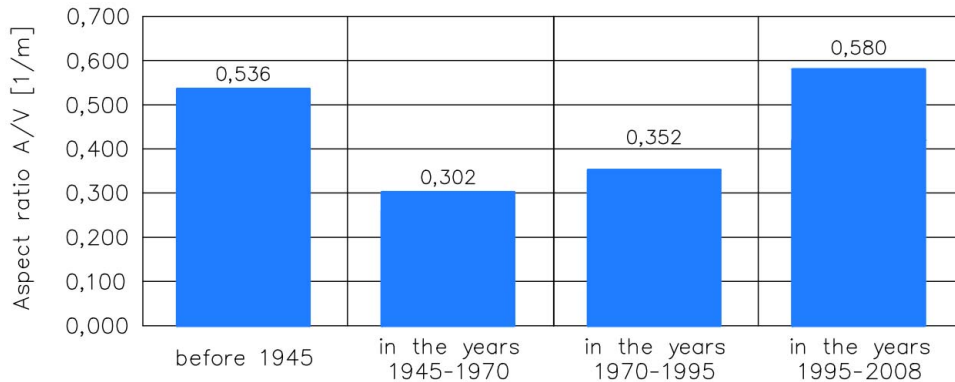

Fig.6. Aspect ratio A/V [1/m] of the buildings analysed.

According to KAPE [7] the aspect ratio of a building can be reduced by designing a building as a simple solid. Figure 7 presents the results of research on the value of the indicator of the demand for usable heating and ventilation energy relative to the aspect ratio of a building. The research was carried out for detached houses and apartment houses in different towns [7].

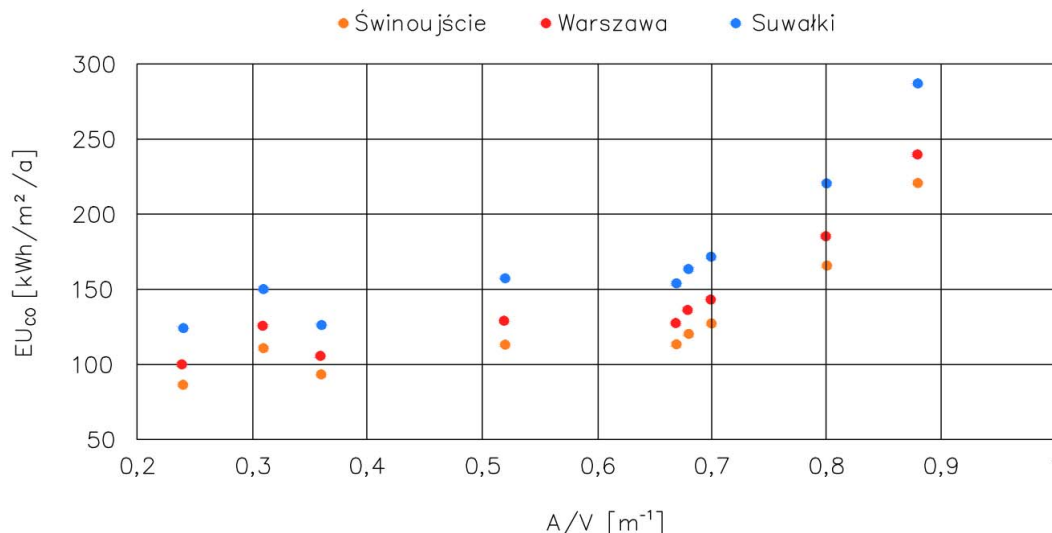

Fig.7. Indicator of the demand for usable heating and ventilation energy in buildings according to WT 2008 relative to the aspect ratio A/V [7].

An analysis of geometry reveals that changing the aspect ratio results in different surface areas for an equivalent floor area (Figs 8 and 9). Designs that require more surface area will thus have a greater quantity of heat transfer. The effect of the aspect ratio on the exterior surface area will have a larger impact on smaller building footprints (Fig.10). The minimum surface area is achieved with a 1:1 aspect ratio.

However, in the presence of solar radiation, the ideal aspect ratio becomes a balance of heat loss and gain.

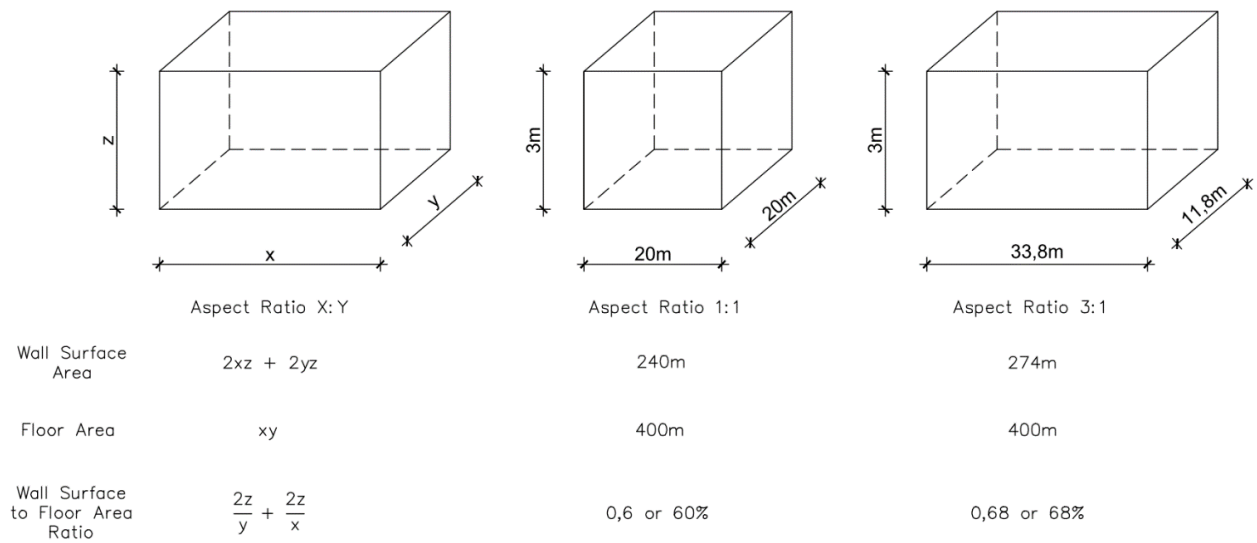

Fig.8. Geometrical relationship between surface area and the aspect ratio [1].

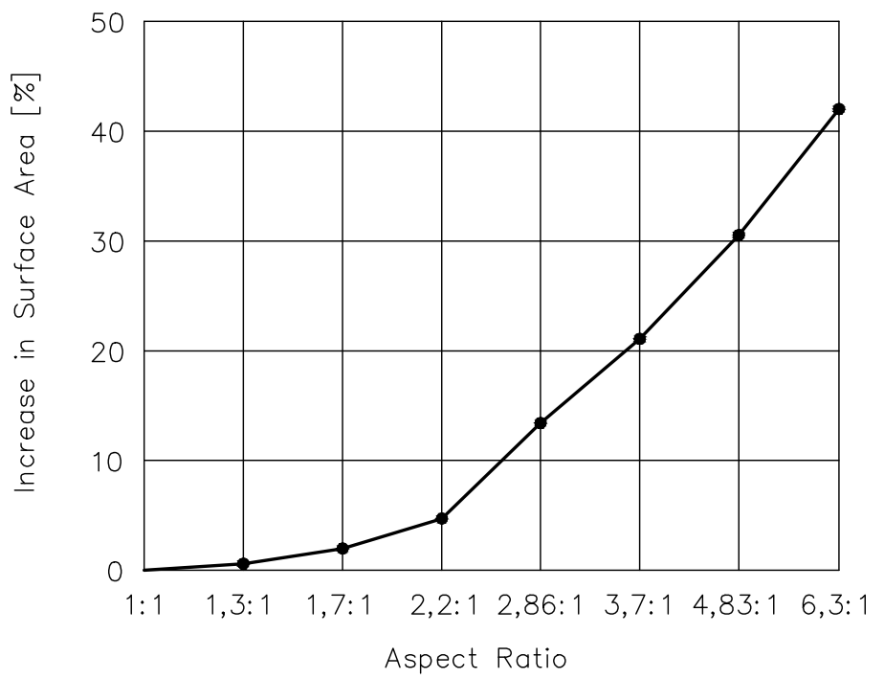

Fig.9. Increase in exterior surface area relative to a 1:1 aspect ratio [1].

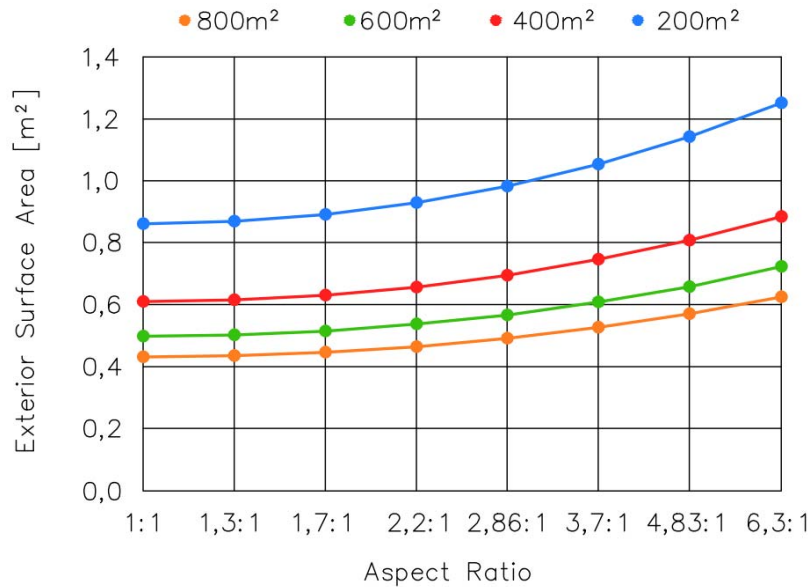

Fig.10. Exterior wall surface area per square meter of floor area for various building footprints with an assumed floor to floor height of 3 m [1].

## 2. Analysis of energy consumption in the building analysed

### 2.1. Orientation to the east-west or north-south axis

According to McKean and Fung [1] the envelope’s efficiency is often discussed in terms of its thermal properties in heat transfer by the process of conduction, convection and radiation. The transfer of thermal energy occurs at the exterior surface of the building. The total surface area subject to thermal transfer is a function of its dimensions or aspect ratio. The aspect ratio quantifies the building’s footprint in a ratio of length and width ( $x:y$ ) and allows the comparison of the surface area amongst different building designs. The change in the aspect ratio can be described to increase relative to the east-west or north-south axis for orthogonal building arrangements. An increase in the aspect ratio can vary the amount of building envelope subject to solar radiation (Fig.11).

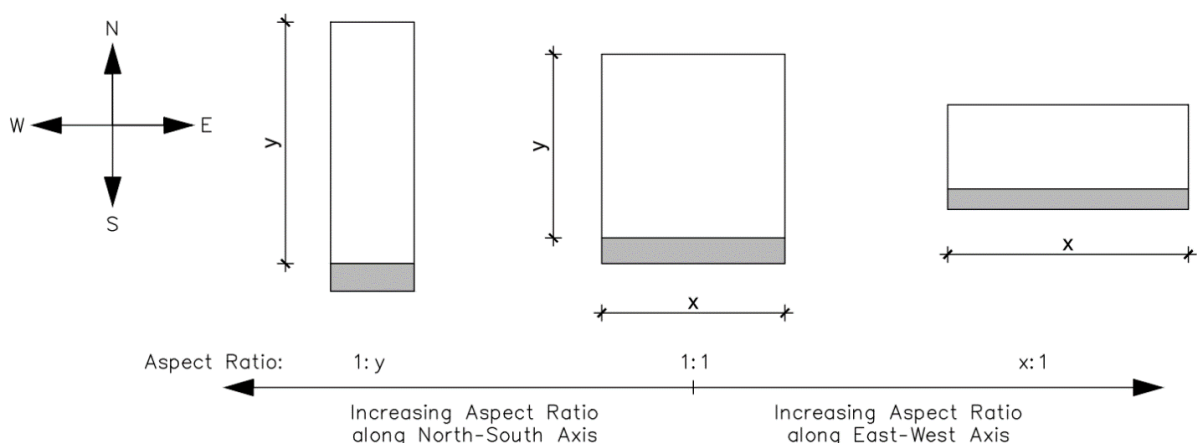

Fig.11. The increase of building dimensions ( $x, y$ ) will change the aspect ratio along a particular axis [1].



The building’s aspect ratio determines the amount of surface area from which heat will be transferred to and from the environment. Minimizing the amount of surface area reduces energy transfer [8]. The demand for energy in buildings largely depends on their orientation in relation to the east-west or north-south axis, especially the elevation with the most glazing.

The rooms oriented to the strongest sunlight will get the largest amount of solar energy, which will be a “free” gain of thermal energy. Therefore, buildings whose glazed elevations are oriented to the south, then the east and the west will benefit the most from solar energy, and thus will have a smaller demand for heating energy. Table 1 presents the orientation to the east-west or north-south axis of the main elevations of the buildings analysed. It is surprising that as many as 37% of the buildings are oriented to the north, 28% to the south, 18% to the east and the same number to the west.

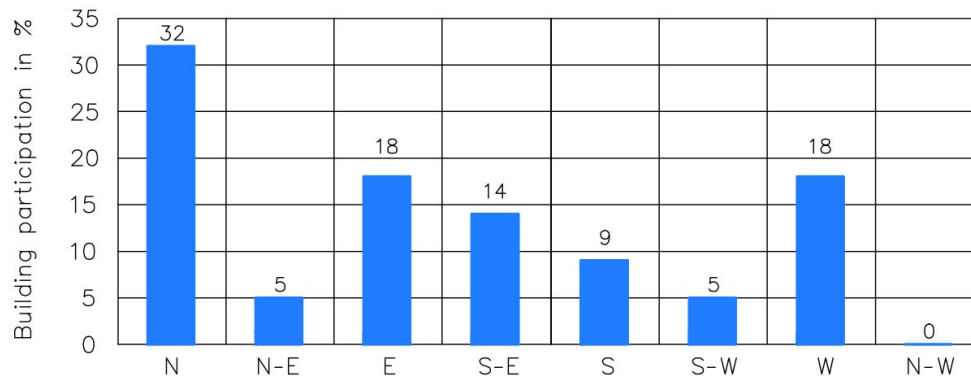

Fig.12. Orientation of buildings in relation to the east-west or north-south axis.

It often happens that the shape of the plot, the surrounding buildings or the layout of flats on both sides pose the most difficult problem to solve effectively, prevent a favourable orientation of buildings, especially their most glazed elevations Fig.12.

**2.2. Consumption of thermal energy for heating and ventilation, usable hot water and electrical energy**

Table 1 presents energy consumption for central heating, usable hot water and electrical energy in the buildings analysed, comparing them with the aspect ratio of the buildings.

These values are presented according to the year of completion and energy consumption (Fig.13a) and they are given in % (Fig.13b).

Table 1. Comparison between the total energy consumption in the buildings and their aspect ratio [9].

Year of completion	before 1945	1945-1970	1970-1995	1995-2008
Total energy for central heating, usable hot water and electrical energy [ <i>kWh/m<sup>2</sup>a</i> ]	272	203	238	229

The data are presented in *kWh/ m<sup>2</sup> a* per *1 m<sup>2</sup>* of usable surface area of the building. As can be seen the greatest demand for heating energy was found in buildings built before 1945, i.e., about *180 kWh/m<sup>2</sup>a* (Fig.13a).

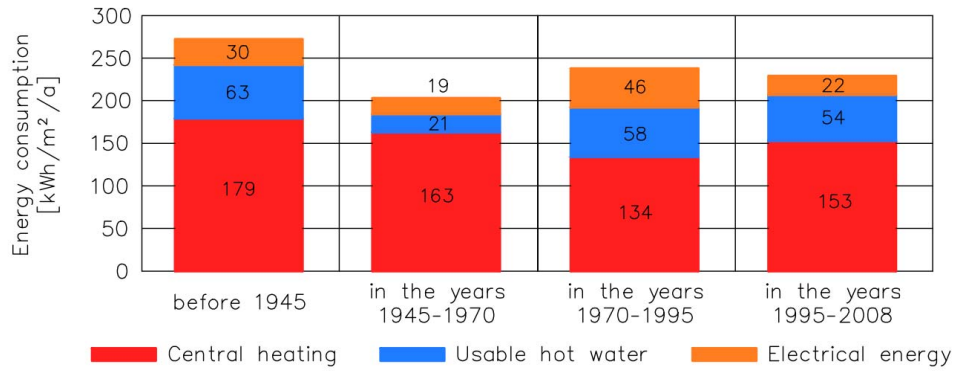

Fig.13a. Energy consumption for central heating, usable hot water and electrical energy.

The main reason for this is that in most cases the buildings analysed did not have thermal insulation. The buildings built in the following years consumed less and less energy for central heating. The buildings built in the years 1945-1970 consume on average about  $163 \text{ kWh/m}^2\text{a}$ , and those built in the years 1970-2008 consume from  $134$  to  $153 \text{ kWh/m}^2\text{year}$ . In the case of usable hot water the problem is different. Consumption of energy for usable hot water tends to decrease over the years. Before 1945 the buildings in the group analysed consumed as much as  $\text{kWh/m}^2\text{a}$ .

In the years 1975-1990 energy consumption decreased to  $58 \text{ kWh/m}^2\text{a}$ , reaching a value of  $54 \text{ kWh/m}^2\text{a}$  in the years 1995-2008. However, energy consumption in the buildings built in the years 1945-1970 does not confirm this trend, which may result from errors of measuring devices or the fact that the inhabitants are just too careful about saving energy.

The analysis of electrical energy consumption indicates that it is between  $19 \text{ kWh/m}^2\text{a}$  in the years 1945-1970 and  $46 \text{ kWh/m}^2\text{a}$  in the years 1970-1995. Considerable differences and instability in electrical energy consumption may result from the fact that in some of the buildings there are areas used by services, which consume much more electrical energy than those used as dwellings.

It is noteworthy that usually about 70-80% of total energy is used for heating (Fig.13b), on average about 10-25% of total energy for usable hot water and about 10-20% for electrical energy.

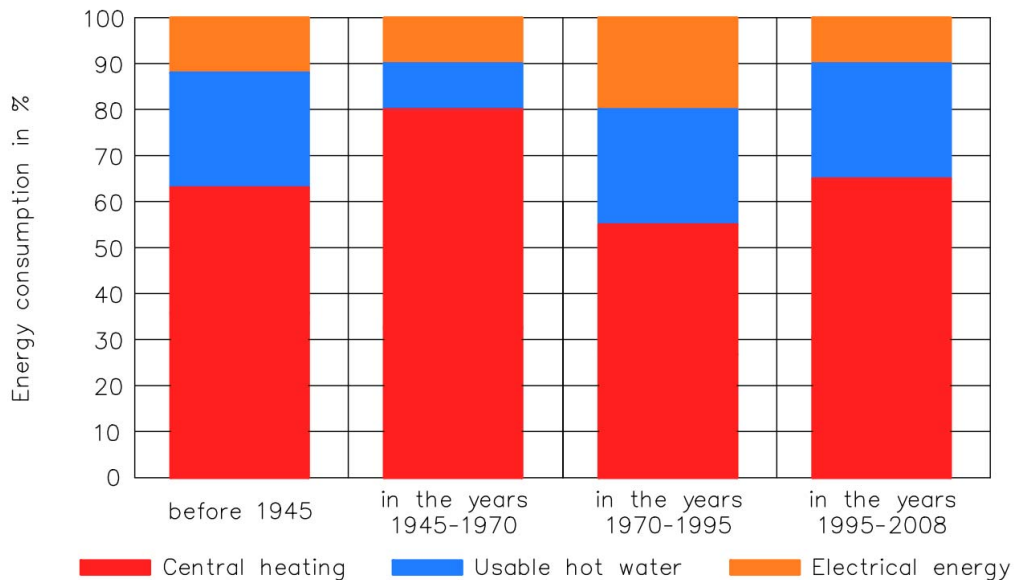

Fig.13b. Energy consumption for heating, ventilation, usable hot water and electrical energy in the group of buildings subjected to analysis.

A comparison between the above values and the aspect ratio of the buildings in each group shows that the character of the change in the total energy consumption value is similar to the changes in the aspect ratio  $A/V$  (Tab.1).

It can be seen that the lowest energy consumption takes place in the buildings with the smallest aspect ratio, i.e., buildings built between 1945 and 1970 (their total energy consumption is about  $203 \text{ kWh/m}^2\text{a}$  with  $A/V = 0.302 \text{ [1/m]}$ ), as well as in the buildings built in the years 1970-1995 (their total energy consumption is about  $238 \text{ kWh/m}^2\text{a}$  with  $A/V = 0.352 \text{ [1/m]}$ ).

The highest energy consumption takes place in the buildings with the largest aspect ratio value. These are the buildings built before 1945 (their energy consumption is about  $272 \text{ kWh/m}^2\text{a}$  with  $A/V = 0.536 \text{ [1/m]}$ ).

The buildings built in the years 1995-2008 have the largest aspect ratio value ( $A/V = 0.580 \text{ [1/m]}$ ). However, they consume less energy than the buildings built before 1945, i.e., about  $229 \text{ kWh/m}^2\text{a}$ . The reason for this is very simple. The buildings built before 1945 were not thermally insulated as was the case with the modern buildings, and it is possible that because of the old heating system they are additionally heated with electric heaters, so their energy consumption is higher.

### 3. Possibilities of thermal modernization

Although the technical condition of the buildings subjected to analysis is usually good (Fig.14), most of them have not been thermally modernized yet. The administrators say that most of the buildings are in good technical condition, i.e., over 60%. About 11% of the buildings analysed are in satisfactory condition. The technical condition of nearly 30% of the buildings is considered to be sufficient. None of the buildings was considered to be in poor technical condition.

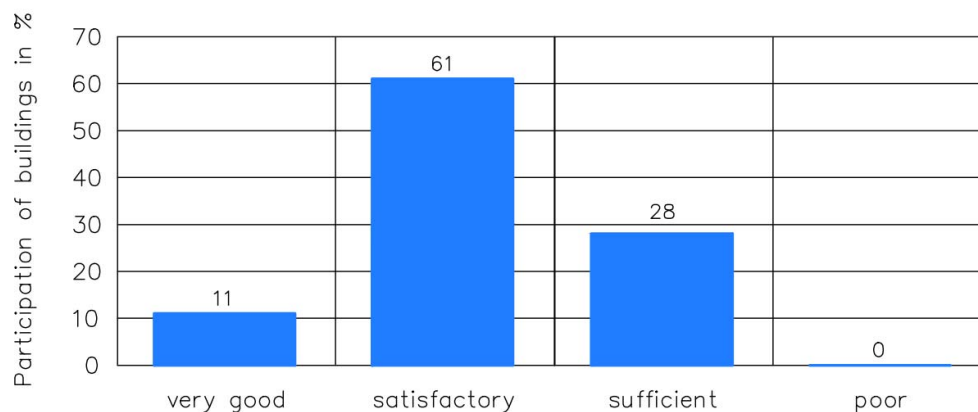

Fig.14. Technical condition of the buildings analysed.

The administrators and inhabitants have noticed that thermal modernization is extremely important and that it considerably improves the quality of life and thermal comfort of the inhabitants as well as increasing the attractiveness of the buildings in terms of possible use for service purposes.

For this reason more and more buildings are being thermally modernized (Fig.15). Some of the buildings analysed, i.e., 30% have already been completely or partly thermally modernized. A smaller part of the buildings, i.e., 20% are in the process of thermal modernization. However, a major part of the buildings, i.e., 50% have not been thermally modernized yet.

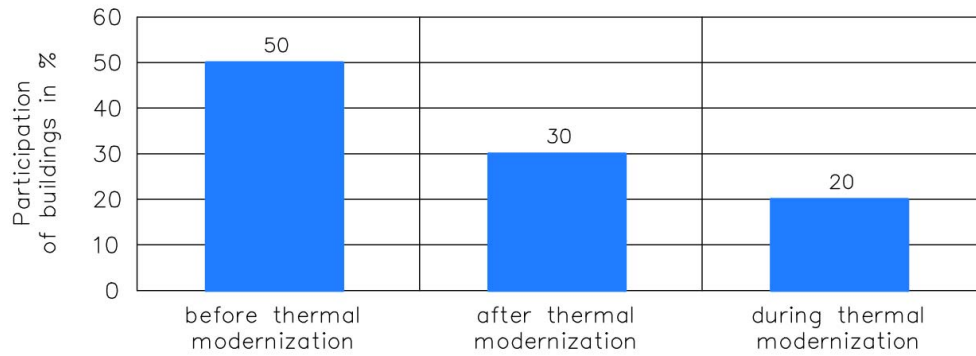

Fig.15. Percentage of buildings undergoing thermal modernization.

The administrators of most of the buildings analysed say that renovation work will commence in the near future (i.e., within 5 years) in order to improve the energy effectiveness of the buildings. The types of renovation work most often mentioned in the reviews are:

- insulating external walls,
- changing window timberwork,
- installing or replacing thermostat valves,
- replacing heating or usable hot water boilers,
- installing solar panels for the usable hot water system.

It has also been noticed that particular inhabitants of the building from the group analysed are more and more aware of the importance of saving energy as well as water (Fig.16).

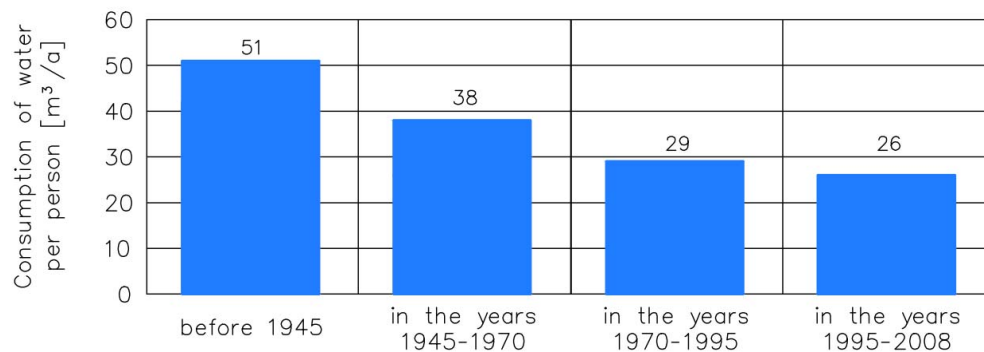

Fig.16. Consumption of water per person in the buildings relative to the year of completion.

Moreover, the inhabitants are made to save water by constantly increasing prices.

Figure 16 shows a noticeable decrease in the consumption of water. In the building built before 1945 the consumption of water is on average  $51m^3 \cdot a$  and it continually decreased to  $26m^3 \cdot a$  in the years 1995-2008.

#### 4. Conclusions

The increasing awareness of both the administrators and inhabitants more and more often causes them to decide to carry out thermal modernization in their buildings. The possibility of obtaining financial aid from the Environmental Protection Bank as well as EU funds often contributes to this decision. The method that is most often used by the administrators is the thermal insulation of the external walls and the roof. Less often it is the thermal insulation of the floor above the unheated basement. In addition, the

inhabitants often contribute to reducing the demand for energy in their buildings by replacing old window woodwork with plastic window frames on their own. Despite the active participation of the administrators and the inhabitants in thermal modernization activities, thermal modernization has not been carried out or is not even planned in more than half of the buildings in the group analysed.

## References

- [1] Philip McKeen and Alan S. Fung (2014): *The effect of building aspect ratio on energy efficiency: A case study for multi-unit residential buildings in Canada*. Buildings - Open Access Journal, Buildings, vol.4, pp.336-354.
- [2] RDH Building Engineering Limited. Energy Consumption and Conservation in Mid and High- Rise Residential Buildings in British Columbia, Canadian Mortgage and Housing Corporation Research Report 2012.
- [3] Energy Efficiency Trends in Residential and Commercial Buildings. U.S Department of energy, Energy Efficiency and Renewable Energy.
- [4] Mikoś J. (1996): Ecological building. Silesian University of Technology, Gliwice.
- [5] Laskowski L. (2005): „Heat protection and energy performance of the building”. Publishing House of the Warsaw University of Technology, Warsaw.
- [6] Energy Manual Sustainable Architecture. Hegger, Fuchs, Stark, Zeumer.
- [7] Energy-efficient homes. Handbook of good practice. National Agency for Energy Conservation S.A. Warsaw, November 2012.
- [8] Danielski I., Fröling M. and Joelsson A. (2012): *The Impact of the Shape Factor on Final Energy Demand in Residential Buildings in Nordic Climates*. Mid Sweden University: Östersund, Sweden.
- [9] Kopietz-Unger J. (2010): The assumptions of spatial planning for climate protection of energy savings. University of Zielona Góra, Zielona Góra.
- [10] Alsabry A. and Żurawski J. (2010): Passive Building – standard and quality assessment, Insulation 10.
- [11] Alsabry A. (2016): *Possibilities of decreasing energy consumption through thermal upgrading in selected buildings in Poland case study: the town of Zielona Góra*. Energy and Buildings, vol.130, pp.811-820.

Received: July 17, 2017

Revised: August 2, 2017