

Technical note

VERIFICATION OF TECHNICAL PARAMETERS AND MODIFICATION OF UPRIGHT EXERCISE BIKE CONSTRUCTION

A.A. STĘPNIEWSKI* and J. GRUDZIŃSKI

Faculty of Production Engineering
University of Life Sciences in Lublin
Akademicka 13 str., 20-950 Lublin, POLAND
E-mails: andrzej.stepniewski@up.lublin.pl
jerzy.grudzinski@up.lublin.pl

In this paper, the technical data provided by the sellers of an exercise bike FALCON SG-911B SAPPHIRE have been verified. After dismantling the bike, the dimensions of the components of the transmission of motion were measured and the mass parameters of the flywheel were set. In order to increase the mass moment of inertia reduced to an axis of the crankshaft, construction changes were proposed. The values of the braking torque of the magnetic brake at subsequent resistance levels were measured. The cycling test was performed and the distance, calories burned and heart rate read from the counter were verified computationally.

Key words: exercise bike, drive system, flywheel, ergometer, technical data.

1. Introduction

Cycling has a beneficial effect on the respiratory and circulatory system; it improves physical fitness and immunity. While cycling, muscles of the legs and abdomen are working intensively. The joints of the hip, knee and ankle are strengthened. Cycling causes fat burning, and improves mood. Therefore, most of the work related to cycling applies to health analyses, ways of training and testing of body movement geometry. There were conducted computer simulation studies, allowing a generalization of the phenomena occurring between the bicycle and the cyclist. They used musculoskeletal models of the human body [1, 2, 3]. Motion geometry analyses of the lower limb and muscle loads were performed in order to optimize the construction of bicycles [4, 5, 6], improve sport performance [7] and increase the effectiveness of rehabilitation after injuries and knee reconstructions [8]. Using EMG measuring method, the waveforms of angular changes [9] and loads in the joints [10] were measured. Using a camera, the movement of the body was studied in order to evaluate the aerodynamic loads [11]. The role of the movements of the upper part of a cyclist's body [12] as well as the effectiveness of the methods adopted for determining aerodynamic resistance were analyzed [13, 14]. The effects of movements in the joints in the individual pedalling zones [15] and the influence of the mass parameters and applied gear ratios on the velocity and expenditure of energy were determined [16, 17].

Stationary bikes are used mostly in autumn and winter. Depending on the construction of the bicycle, there are bikes with a mechanical, magnetic or electromagnetic brake. The most elaborate are spinning bikes, which were originally designed for professional cyclists to train off-season. Bicycles equipped with a power meter of the leg muscles and the counter of calories burned are called ergometer bicycles or cycloergometers. Ergometers are used in physical rehabilitation of the lower limbs, by the cyclists and to lose weight as well as in orbital stations to prevent muscle relaxation and maintain proper operation of the cardiovascular system in microgravity.

* To whom correspondence should be addressed

In the decision to purchase a particular model of a stationary bike for home use there are helpful blogs with user feedback and mainly technical data given by sellers on the Internet sites. A potential customer who decides to purchase certain equipment selects a compromise between the price and officially published parameter values, believing in their reliability.

The aim of this study is to verify the technical data provided by the retailers of exercise bikes, checking the correctness of the readings measuring calories burned, speed and pulse and to propose construction changes to improve performance parameters.

2. Materials and methods

The object of the research was a stationary bike FALCON SG-911B SAPPHIRE (Fig.1). Motion transmission system consists of the crankshaft having a pulley driven through the pedals (with the possibility of pedalling backwards), the flywheel driven by a belt and a mechanism of resistance.



Fig.1. Stationary exercise bicycle SG-911B FALCON.

Retailers of the bike SG-911B FALCON, provide the following technical data: 8-level adjustable resistance, quiet operation of magnetic resistance mechanism, massive flywheel "weighing" 7kg providing "smooth motion" during exercise, heart rate sensors. In addition, they give the dimensions, utility class, adjustable angle of handlebars, and permissible "weight" of the user. They pay attention to aesthetic qualities and transport rollers.

The bicycle was dismantled and the flywheel was weighed. The value of the mass moment of inertia of the flywheel reduced to the rotational axis of the crankshaft was determined. There were calculated values of mass moment of inertia reduced to an axis of rotation of the crankshaft in an ordinary bicycle when riding on the most frequently used transmission ratio. Construction changes were proposed in the exercise bike allowing getting similar values of the reduced mass moment of inertia. Then the values of the braking torque of the magnetic brake were measured and test "ride" was conducted with further levels of resistance, during which the bike speed, distance, energy and pulse of the exerciser were read from a bike computer. The readings were verified by calculation using basic dependencies.

3. Actual parameters of the bicycle

3.1. Flywheel

The information on the importance of the mass of the flywheel is only indirectly true, because in a rotary motion the mass moment of inertia of the flywheel is important depending more on its geometry than weight. The removed flywheel was weighed and measured (Fig.2).

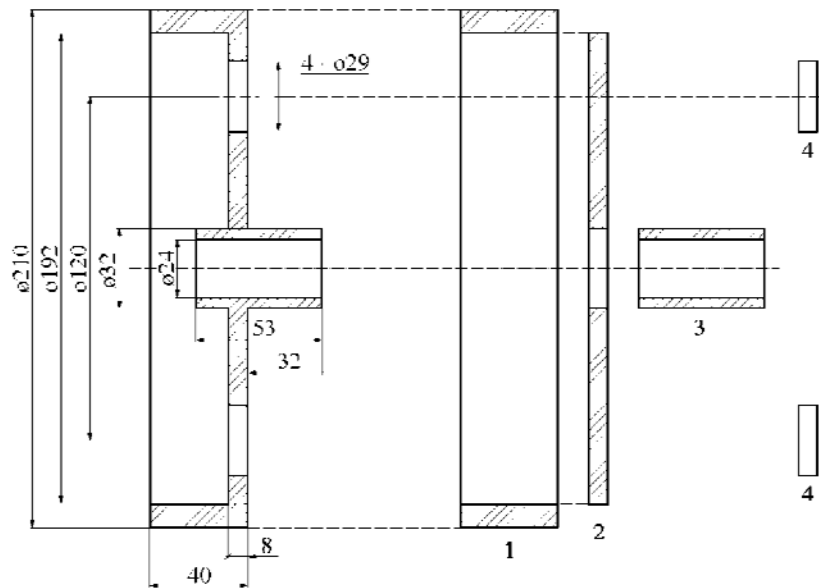

Fig.2. The flywheel of exercise bicycle SG-911B FALCON.

The real weight of the flywheel is $m_k=3.22 \text{ kg}$. After dividing the flywheel into 4 cylinders (Fig.2) their volume was determined V_i ($i= 1...4$): $V_1=2.27 \cdot 10^{-4} \text{ m}^3$, $V_2=2.25 \cdot 10^{-4} \text{ m}^3$, $V_3=1.86 \cdot 10^{-5} \text{ m}^3$, $V_4=2.11 \cdot 10^{-5} \text{ m}^3$ and a specific mass ρ_k , of the wheel material was calculated

$$\rho_k = \frac{m_k}{\sum_{i=1}^{i=3} V_i - V_4} = \frac{3.22}{4.50 \cdot 10^{-4}} = 7155 \text{ kg} \cdot \text{m}^{-3} \quad (3.1)$$

and the masses of individual cylinders m_i , ($i= 1 \div 4$): $m_1=1.627 \text{ kg}$, $m_2=1.611 \text{ kg}$, $m_3=0.133 \text{ kg}$, $m_4=0.151 \text{ kg}$.

The value of the mass moment of inertia of a hollow cylinder I_i was determined by the relationship

$$I_i = 0.125m_i(D_i^2 + d_i^2) \quad (3.2)$$

where

m_i – cylinder mass i [kg],

D_i – the outer diameter of the cylinder i [m],

d_i – the inner diameter of the cylinder i [m].

Thus, the mass moment of inertia of the flywheel, taking into account Steiner's Theorem (for four hollows) is determined by the relationship

$$I_k = 0.125 \left\{ \left[\sum_{i=1}^{i=3} m_i (D_i^2 + d_i^2) \right] - m_4 (D_4^2 + 2D_{r4}^2) \right\} \quad (3.3)$$

where

m_4 – the mass of the removed material of the four hollow cylinders [kg],

D_4 – diameter of the hollow [m],

D_{r4} – diameter of the hollows arrangements [m].

After substituting the figures, we obtained $I_k=0.02356 \text{ kg}\cdot\text{m}^2$, so the mass moment of inertia of the flywheel reduced to axis of rotation of the crankshaft I_w

$$I_w = I_k i_w^2 \quad (3.4)$$

where $i_w=210/32=6.5625$ is the gear ratio between the crankshaft and flywheel, so $I_w \approx 1.0146 \text{ kg}\cdot\text{m}^2$.

3.2. The magnetic brake and ergometer indications

A bicycle having been used for 1.5 years for approx. 0.5 hours per day was tested, in which, according to subjective feelings, the braking torque was reduced, presumably due to partial demagnetization of the magnets. The values of the braking torque M_w of magnetic brake system were measured on each of eight resistance levels and a test "ride" was performed at subsequent levels of resistance.

After doing 50 revolutions l_w , so that the average velocity v_s was constant at approx. 10 km/h , the time t [min], the displacement s [km], the pulse p and calories burned W_z were read from the meter [cal]. The measurement results are shown in Tab.1.

Table 1. The results of measurements and calculations.

Resistance level	Measurement					Calculations
	M_w [N·m]	t [min]	s [km]	p [1/min]	W_z [cal]	W_o [cal]
1	0.11	1.18±0.01	0.21	90	9.7±0.1	8.25
2	0.19			95		14.26
3	0.30			100		22.51
4	0.34			120		25.51
5	0.44			121		33.02
6	0.51			121		38.27
7	0.53			122		39.77
8	0.54			122		40.52

The resistance level to magnetic brake had no impact on the indications of the ergometer. After dismantling the handlebar, it turned out that the bicycle had only two sensors, one for measuring the number of revolutions of the crankshaft (red switch), the other one for measuring the pulse. There is no sensor for measuring the resistance level, even in the form of resistance-changing knob mounted in the axis or a potentiometer connected to the measuring system. The changes in resistance from level 5 to 8 are small and hardly perceptible while pedaling.

4. Proposed changes in the construction and verification of measurements

4.1. Construction changes in the system of transmission of motion

In an ordinary bicycle equipped with the derailleur, the transmission can usually be changed from $22/34 = 0.647$ to $42/14 = 3.000$, so a reduced moment of inertia in the axis of rotation of the crankshaft I_r varies in the range of $0.42I_r$ to $9.00I_r$. In order to determine such an average value of the mass moment of inertia, that would allow a comparison of pedaling an exercise bike to pedaling an ordinary bicycle, an average value of the mass moment of inertia in an ordinary bicycle with a rider should be computed reduced to the axis of rotation of the crankshaft I_s , which, with omission of components having a very small impact on the value, is determined by the relationship

$$I_s(i_s) = i_s^2 \left\{ m_r R_o^2 + m_o \left[(R_o - r_o)^2 + 0.75 r_o^2 \right] \right\} \quad (4.1)$$

where

i_s – the arithmetic mean of the extreme gear ratios in a ordinary bike ($i_s = 1.82$),

m_o – mass of the two wheels of the bike [kg],

m_r – mass of the bike with cyclist [kg],

r_o – the mean radius of the tire [m],

R_o – tread radius of the tire [m].

Assuming an average weight of the cyclist and the figures given in Tab.2, there is obtained $I_s \approx 35 \text{ kg} \cdot \text{m}^2$. The obtained value of moment of inertia reduced to the axis of rotation of the crankshaft is more than 30 times greater than the moment of inertia in a stationary bike.

Table 2. Masses and dimensions of an ordinary bike included in the calculation.

Name of element	Designation	Name of parameter	Value	Unit
Wheels	m_o	Mass	4.65	kg
Tire 28x2.0	R_o	Tread radius	0.364	m
	r_o	Radius of tire section	0.025	m
Chainring	$z_{p1}/z_{p2}/z_{p3}$	Number of teeth	22/32/42	Item
Cassette	$z_{11}/z_{12}/z_{13}/z_{14}/z_{15}/z_{16}$	Number of teeth	14/18/22/26/30/34	Item
Bicycle	m_c	Total mass	12.65	kg

It is possible to increase the value of the mass moment of inertia 30 times in two ways: having a larger diameter of the flywheel with a concomitant increase in weight or increasing the gear ratio between the crankshaft and flywheel. It is not difficult to prove on the basis of the basic dependences that in order to fulfill the posed condition it would be necessary to increase the diameter of the wheel to approx. 0.5 m and to increase the weight to approx. 200 kg. That sounds ridiculous in relation to the design and dimensions of the bike proposed by the manufacturer. The solution could be using the elements of a bicycle after doing relatively simple "modifications" involving the addition of a second-degree gear ratio. For this purpose, in place of the flywheel, a second pulley and flywheel put in the axis of the crankshaft should be used - Fig.3. After making construction changes, the altered value of the mass moment of inertia in an axis of rotation of the crankshaft I_{wz} will be

$$I_{wz} = 0.02356 \text{ kg} \cdot \text{m}^2 \cdot \left(\frac{210}{32} \cdot \frac{210}{32} \right)^2 \approx 44 \text{ kg} \cdot \text{m}^2.$$

The flywheel should be carefully balanced, which will have 6.56- fold increased angular velocity and 6.56- fold decreased braking torque of magnetic brake by applying weaker magnets or locating them in a distance from the inner rim of the side surface of the flywheel. This is the advantage of the solution due to the reduction of the impact of eddy currents causing heat release. Instead of the brake, a small resistance-loaded generator can be applied, which could be used additionally to charge the batteries.

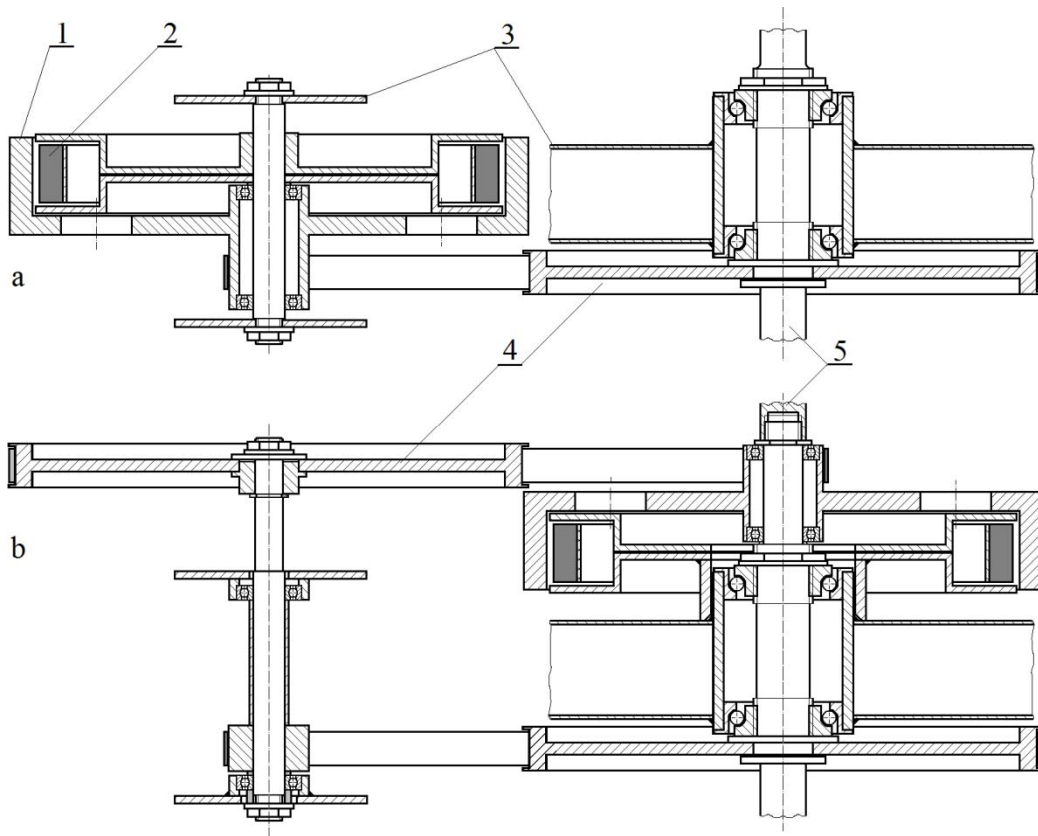

Fig.3. The transmission of motion to the flywheel of stationary bicycle SG-911B; a– existing solution, b– proposed change; 1 – flywheel, 2 – magnet, 3 – bicycle frame, 4 – pulley, 5 – crankshaft.

4.2. Verification of ergometer indications

To check the reliability of indications there were calculated:

- the gear ratio i_p , at which the displacement of an ordinary bike will be similar to that indicated by the measurement system of a stationary bicycle

$$i_p = \frac{s}{2\pi R_o l_w} = \frac{210}{2\pi \cdot 0.364 \cdot 50} = 1.84, \quad (4.2)$$

- average speed resulting from covering indicated displacement and time

$$v_s = \frac{s}{t} = \frac{0.210 \cdot 60}{1.18} = 10.68 \frac{km}{h}, \quad (4.3)$$

- work done W_o [cal] for subsequent loads according to the relationship

$$W_o = 0.4777\pi M_w l_w. \quad (4.4)$$

The determined gear ratio is almost identical to the average gear ratio in the ordinary bicycle. The designated average speed can be considered correct. Its slightly higher value results from the difficulty of

maintaining uniform motion during the measurement. Indications of pulse were consistent with indications of an articulated heart rate monitor. The calculated values are given in the last column of Tab.1.

5. Discussion and conclusions

Internet users as well as the professionals publish on their blogs the view that the weight of the flywheel greater than 6 kg provides a completely "smooth" ride and makes it easier to "maintain motion over dead point of the pedal". Therefore, the most important parameter determining the choice of a model is the mass of the flywheel. Given by retailers of the bike SG-911B FALCON SAPPHIRE the mass of the flywheel 7 kg is false, its real value is 3.22 kg. Another very important aspect for the correctness of the training and rehabilitation is the work done, or calories burnt. The applied measurement method involving only counting the revolutions of the crankshaft without taking into account the resistance level of the magnetic brake gives erroneous results. It is possible to introduce fairly simple and inexpensive construction changes, which will bring closer the parameters of this bike to the parameters of an expensive spinning bike with a large flywheel and will result in obtaining the correct measurement results. According to the authors of this paper, introduction and testing the proposed changes will contribute to the improvement of this bike, which with its defects also has many advantages, which include solid and aesthetic finish, comfortable seat with adjustable height, elegant handlebar with the possibility of tilting, leveling solid platform pedals.

Based on the analysis, the following conclusions and recommendations can be formulated:

1. Over 30-fold increase in the reduced moment of inertia is possible by the use of a second level gear ratio according to the proposed solution.
2. More than 6.56- fold reduction in braking torque allows the use of a small resistance-loaded generator placed in the axis of the flywheel,
3. By measuring the transmitted power at the load of the generator, the work done can be precisely defined and additionally it can be used for charging batteries supplying the measuring system and simultaneously eliminate the formation of eddy currents causing heat release.
4. In order to make riding a stationary bike similar to riding a typical bicycle, the usefulness of the freewheel should be considered.

References

- [1] Andersen M.S., Damsgaard M., MacWilliams B. and Rasmussen J. (2010): *A computationally efficient optimisation-based method for parameter identification of kinematically determinate and over-determinate biomechanical systems*. – Computer Methods in Biomechanics and Biomedical Engineering, vol.13, pp.171-183.
- [2] Dahmen T., Byshko R., Saupe D., Roder M. and Mantler S. (2011): *Validation of a model and a simulator for road cycling on real tracks*. – Sports Eng, vol.14, pp.95–110.
- [3] Rasmussen J. (2010): *Challenges in human body mechanics simulation*. – Procedia IUTAM, vol.2, pp.176-185.
- [4] Bini R.R., Diefenthaler F. and Mota C.B. (2010): *Fatigue effect on the coordinative pattern during cycling: Kinetics and kinematics evaluation*. – J. of Electromyography and Kinesiology, vol.20, pp.102-107.
- [5] Bini R.R., Hume P.A., Lanferdini F.J. and Vaz M. A. (2013): *Effects of moving forward and backward on the saddle on knee joint forces during cycling*. – Physical Therapy in Sport, vol.14, pp.23-27.
- [6] Wanich T., Hodgkins Ch., Columbier J.A., Muraski E. and Kennedy J.G. (2007): *Cycling injuries of the lower extremity*. – J. Am. Acad. Orthop. Surg., vol.15, pp.748-756.
- [7] Koninckx E., Van Leemputte M. and Hespel P. (2010): *Effect of isokinetic cycling versus mass training on maximal power output and endurance performance in cycling*. – European Journal of Applied Physiology, vol.109, pp.699-708.
- [8] Tamborindeguy A.C. (2011): *Does saddle height affect patellofemoral and tibiofemoral forces during bicycling for rehabilitation*. – Journal of Bodywork and Movement Therapies, vol.15, pp.186-191.

- [9] Cockcroft S.J. (2011): *An evaluation of inertial motion capture technology for use in the analysis and optimization of road cycling kinematics*. – Stellenbosch University.
- [10] Park S.-Y., Lee S.-Y., Kang H. C. and Kim S.-M. (2012): *EMG analysis of lower limb muscle activation pattern during pedaling experiments and computer simulations*. – Int. J. of Precision Engineering and Manufacturing, vol.13, No.4, pp.601-608.
- [11] Diefenthaler F., Carpes F.P., Bini R.R., Mota C.B. and Guimarães A.C.S. (2010): *Methodological proposal to evaluate sagittal trunk and spine angle cyclists: Preliminary study*. – Brazilian Journal of Biomotricity, vol.2, No.4, pp.284-293.
- [12] Moore J.K., Kooijman J.D.G., Schwab A.L. and Hubbard M. (2011): *Rider motion identification during normal bicycling by means of principal component analysis*. – Multibody Syst. Dyn., vol.25, pp.225-244.
- [13] Debraux P., Grappe F., Manolova A.V. and Bertucci W. (2011): *Aerodynamic drag in cycling: methods of assessment*. – Sports Biomechanics, vol.10, No.3, pp.197-218.
- [14] Defraeye T., Blocken B., Koninckx E., Hespel P. and Carmeliet J. (2010): *Aerodynamics study of different cyclic positions: CFD Analysis and full scale wind tunnel tests*. – J. Biomechanics, vol.43, pp.1262-1268.
- [15] Höchtel F., Böhm H. and Senner V. (2010): *Prediction of energy efficient pedal forces in cycling using musculoskeletal simulation models*. – Proc. Engineering, vol.2, pp.3211-3215.
- [16] Rankin J.W., Neptune R.R. (2008): *A theoretical analysis of an optimal changing shape to maximize crank power during isokinetic pedaling*. – J. of Biomechanics, vol.41, pp.1494-1502.
- [17] Stepniewski A.A. and Grudziński J. (2014): *The Influence of mass parameters and gear ratio on the speed and energy expenditure of a cyclist*. – Acta of Bioengineering and Biomechanics, vol.16, No.2, pp.47-55.

Received: August 3, 2016

Revised: September 13, 2016