

ITERATIVE METHOD OF CALCULATION OF ORIGINALLY CIRCULAR-SYMMETRIC STRUCTURES

Stanisław PRYPUTNIEWICZ, Tomasz PRYPUTNIEWICZ
University of Zielona Góra, prof. Z. Szafrana St. 2,
65-516 Zielona Góra, Poland

The paper proposes an iterative method of calculation of modified, originally circular-symmetric structures. The method applies a cyclical (or quasi-cyclical) stiffness matrix of the original structure in each iteration step. A lot of modified systems which differ considerably from circular-symmetric ones (lack of some elements, strengthening, additional supports) have been calculated. The obtained results indicate that although the algorithm is not unconditionally convergent, exact solutions are often received even for considerable changes in the original structure. Operations on considerably smaller matrices than the full ones describing a system completely, compensate for the necessity of performing a greater number of iterations than when applying other methods of modification.

Keywords: circular-symmetric structures, modification, cyclic matrices

1. INTRODUCTION

The strive for designing better and better structures for the assumed criteria leads to numerous changes in the originally assumed solution. To avoid multiple calculations of the whole structure, various methods of modification of the structure are suggested. They most often consist in solving a considerably smaller task than the original one, ensuring however obtaining satisfying solutions [3]. The methods of structure modifications are applied not only in optimisation algorithms but also in calculations of reinforced structures or inconsiderably different from the regular ones and because of their regularity the calculation methods are simple. Circular-symmetric structures of various kinds are an example. Among the numerous methods of calculation of circular-symmetric structures reduced to a discrete system, two equivalent ones may be distin-

guished: a method applying discrete Fourier transformation [6] and a method applying spectral properties of cyclic or quasi-cyclic matrices [1]. The latter method has been used in the paper.

The analysed modified linear-elastic structures are not circular-symmetric ones. To maintain the properties of the original regular structure, we apply an iterative method, with the stiffness matrix modification replaced by the modification of the load vector. We will use a constant stiffness matrix in each step of iteration. The similar iterative method has been used for calculations of suspension, geometrically non-linear structures [3,4], using discrete Fourier transformations, though. The method of iteration seems to be useful for calculation structures made of a linear viscoelastic material, using approximation of stresses proposed in [7,8] and [2].

The problem formulation as well as the description of the algorithm are presented in chapter two. The third part contains the suitability analysis of the proposed method for calculation of modified frames, grids and spatial trusses.

2. PROBLEM FORMULATION

The subject of the analysis are linear-elastic, originally circular-symmetric structures, which can be theoretically divided into finite elements so that the nodes of the elements are placed on regularly distributed meridians and parallels. They might be both rod and shell structures. Parameter n ($n \geq 3$) which is equal to the number of the meridians shall be called the rate of periodicity.

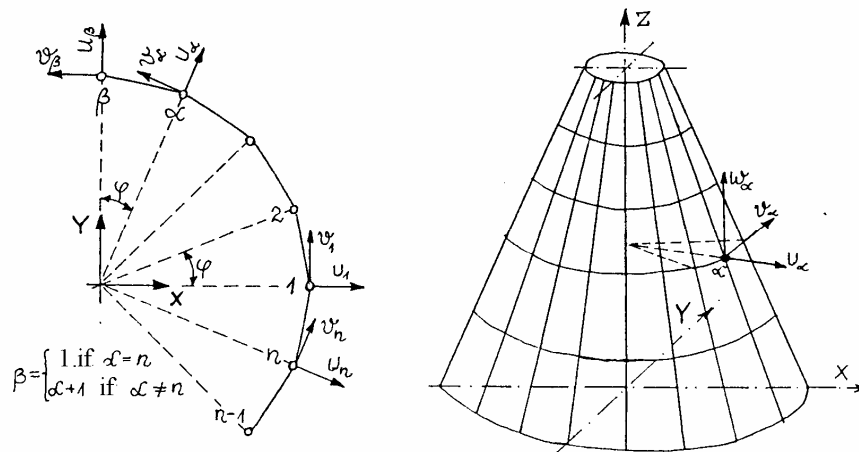

Fig. 1 Discrete scheme of the structure

If the degrees of freedom of the nodes are referred to co-ordinate systems connected with particular meridians (Fig.1), we shall receive, applying displacement methods, the following symmetrical p-cyclic system of equations of mn order with quasi-elements of m order:

$$\mathbf{Kq} = \mathbf{Q} \quad (1)$$

or in an extended form

$$\begin{bmatrix} \mathbf{K}_1 & \mathbf{K}_2 & \dots & \mathbf{K}_p & & \mathbf{K}'_p & \dots & \mathbf{K}'_2 \\ \mathbf{K}'_2 & \mathbf{K}_1 & \mathbf{K}_2 & \dots & \mathbf{K}_p & & \mathbf{K}'_p & \dots \\ \dots & \mathbf{K}'_2 & \mathbf{K}_1 & \mathbf{K}_2 & \dots & \mathbf{K}_p & & \mathbf{K}'_p \\ \mathbf{K}'_p & \dots & \mathbf{K}'_2 & \mathbf{K}_1 & \mathbf{K}_2 & \dots & \mathbf{K}_p & \\ & \mathbf{K}'_p & \dots & \mathbf{K}'_2 & \mathbf{K}_1 & \mathbf{K}_2 & \dots & \mathbf{K}_p \\ \mathbf{K}_p & & \mathbf{K}'_p & \dots & \mathbf{K}'_2 & \mathbf{K}_1 & \mathbf{K}_2 & \dots \\ \dots & \mathbf{K}_p & & \mathbf{K}'_p & \dots & \mathbf{K}'_2 & \mathbf{K}_1 & \mathbf{K}_2 \\ \mathbf{K}_2 & \dots & \mathbf{K}_p & & \mathbf{K}'_p & \dots & \mathbf{K}'_2 & \mathbf{K}_1 \end{bmatrix} \begin{bmatrix} \mathbf{q}_1 \\ \mathbf{q}_2 \\ \mathbf{q}_3 \\ \dots \\ \mathbf{q}_{n-1} \\ \mathbf{q}_n \end{bmatrix} = \begin{bmatrix} \mathbf{Q}_1 \\ \mathbf{Q}_2 \\ \mathbf{Q}_3 \\ \dots \\ \mathbf{Q}_{n-1} \\ \mathbf{Q}_n \end{bmatrix} \quad (2)$$

The load vector \mathbf{Q} is here an arbitrary vector; the circular symmetry of the load is not required. The parameter m is equal to the number of degrees of freedom of all the nodes placed on the same meridian, whereas, the parameter p describes the degrees of filling of the stiffness matrix \mathbf{K} and depends on the number of neighbouring meridians connecting particular finite elements.

According to paper [1], solving the system of equations (2) may be replaced with a repeated process of solving considerably smaller systems of hermitean equations.

$$\mathbf{\Lambda}_j (\mathbf{X}_j - i\mathbf{Y}_j) = \mathbf{S}_j - i\mathbf{T}_j, \quad j=1,2,\dots,n, \quad i = \sqrt{-1} \quad (3)$$

where for $p < (n+2)/2$

$$\mathbf{\Lambda}_j = \mathbf{B}_j + i\mathbf{C}_j, \quad ,$$

$$\mathbf{B}_j = \mathbf{K}_1 + \sum_{t=2}^p (\mathbf{K}_t + \mathbf{K}'_t) \cos(t-1)j \frac{2\pi}{n}, \quad (4)$$

$$\mathbf{C}_j = \sum_{t=2}^p (\mathbf{K}_t - \mathbf{K}'_t) \sin(t-1)j \frac{2\pi}{n}$$

and

$$\begin{aligned} \mathbf{S}_j &= \frac{1}{\sqrt{n}} \sum_{k=1}^n \mathbf{Q}_k \cos kj \frac{2\pi}{n} , \\ \mathbf{T}_j &= \frac{1}{\sqrt{n}} \sum_{k=1}^n \mathbf{Q}_k \sin kj \frac{2\pi}{n} \end{aligned} \quad (5)$$

Since

$$\mathbf{X}_{n-j} = \mathbf{X}_j, \quad \mathbf{Y}_{n-j} = \mathbf{Y}_j, \quad \mathbf{Y}_{n/2} = \mathbf{Y}_n = 0, \quad 1 \leq j < n/2 \quad (6)$$

Subsystems (3) are solved only $E\left(\frac{n+2}{2}\right)$ times for $j = 1, \dots, E\left(\frac{n}{2}\right), n$.

$E(x)$ means here an integral part of numeral x .

The searched values of displacements of system are determined from relation:

$$\mathbf{q}_k = \frac{1}{\sqrt{n}} \left[2 \sum_{j=1}^{E\left(\frac{n-1}{2}\right)} \left(\mathbf{X}_j \cos kj \frac{2\pi}{n} + \mathbf{Y}_j \sin kj \frac{2\pi}{n} \right) + (-1)^k \frac{1+(-1)^n}{2} \mathbf{X}_{n/2} + \mathbf{X}_n \right], \quad (7)$$

$k = 1, 2, \dots, n$

For the majority of circular-symmetric structures, the nodes belonging to a selected element are placed on two neighbouring meridians after the discretization. For such structures, $p=2$ and the stiffness matrix is simplified to the form:

$$\mathbf{K} = \begin{bmatrix} \mathbf{K}_1 & \mathbf{K}_2 & & & \mathbf{K}'_2 \\ \mathbf{K}'_2 & \mathbf{K}_1 & \mathbf{K}_2 & & \\ & \mathbf{K}'_2 & \mathbf{K}_1 & \mathbf{K}_2 & \\ & & \mathbf{K}'_2 & \mathbf{K}_1 & \mathbf{K}_2 \\ \mathbf{K}_2 & & & \mathbf{K}'_2 & \mathbf{K}_1 \end{bmatrix} \quad (8)$$

containing only the matrixes \mathbf{K}_1 and \mathbf{K}_2 .

The matrices may be determined in a way typical of the finite element method.

Equation (1), after considering the change of the stiffness matrix $\Delta\mathbf{K}$ caused by modification, is written in the following form:

$$(\mathbf{K} + \Delta\mathbf{K})\mathbf{q} = \mathbf{Q} \quad (9)$$

To solve equation (9) we shall apply the following iterative procedure:

$$\mathbf{K}\mathbf{q}^{(1)} = \mathbf{Q}^{(i-1)}, \quad i = 1, 2, \dots \quad (10)$$

relying on the modification of the load vector according to the formulation

$$\mathbf{Q}^{(i-1)} = \mathbf{Q} - \Delta\mathbf{Q}^{(i-1)}, \quad (11)$$

where

$$\Delta\mathbf{Q}^{(i-1)} = \Delta\mathbf{K}\mathbf{q}^{(i-1)}, \quad \mathbf{q}^{(0)} = \mathbf{0}. \quad (12)$$

The iteration is finished when for each displacement

$$\left| \frac{q^{(i-1)} - q^{(i)}}{q^{(i)}} \right| \leq \varepsilon, \quad (13)$$

takes place, where ε is the desired accuracy of calculations.

Where, instead of solving system of equations (10) for each step of iteration, we solve considerably smaller systems of hermitean equations (3) with the corrected coefficients $\mathbf{S}_j^{(i-1)}$ and $\mathbf{T}_j^{(i-1)}$. We shall present the way of calculation of the coefficients for some alternative modifications of the structure.

A. Let's assume that the modification of the structure leads only to the alteration of the stiffness matrix \mathbf{K}_1 assigned to a selected meridian α ($1 \leq \alpha \leq n$). The alteration will be referred to as $\Delta\mathbf{K}_{1\alpha}$. The situation may take place, for example, when the stiffness of the rods overlapping with the meridian α (rods connecting the nodes of the same meridian) is changed or in case of applying additional elastic supports. In this instance, according to the formulation (12), the correction of the load vector concerns only the elements of the vector \mathbf{Q}_α i.e.

$$\Delta\mathbf{Q}_\alpha^{(i-1)} = \Delta\mathbf{K}_{1\alpha} \mathbf{q}_\alpha^{(i-1)}. \quad (14)$$

If we consider it while calculating the coefficients (5), their corrected values may be determined in the following way:

$$\begin{aligned} \mathbf{S}_j^{(i-1)} &= \mathbf{S}_j - \frac{1}{\sqrt{n}} \Delta\mathbf{Q}_\alpha^{(i-1)} \cos \alpha j \frac{2\pi}{n}, \\ \mathbf{T}_j^{(i-1)} &= \mathbf{T}_j - \frac{1}{\sqrt{n}} \Delta\mathbf{Q}_\alpha^{(i-1)} \sin \alpha j \frac{2\pi}{n}, \quad j = 1, 2, \dots, n. \end{aligned} \quad (15)$$

When the modification refers to a few meridians, the corrected values of the coefficients $\mathbf{S}_j^{(i-1)}$ and $\mathbf{T}_j^{(i-1)}$ are calculated from the respective formulations:

$$\begin{aligned}\mathbf{S}_j^{(i-1)} &= \mathbf{S}_j - \frac{1}{\sqrt{n}} \sum_{[\alpha]} \Delta \mathbf{Q}_\alpha^{(i-1)} \cos \alpha j \frac{2\pi}{n} , \\ \mathbf{T}_j^{(i-1)} &= \mathbf{T}_j - \frac{1}{\sqrt{n}} \sum_{[\alpha]} \Delta \mathbf{Q}_\alpha^{(i-1)} \sin \alpha j \frac{2\pi}{n} ,\end{aligned}\quad (16)$$

where summation comprises all the modified meridians.

B. Let's consider now that the modification refers to the elements situated between the neighbouring meridians β and γ , where:

$$\gamma = \begin{cases} \beta+1 & \text{dla } \beta \neq n \\ 1 & \text{dla } \beta = n \end{cases} . \quad (17)$$

The modification results in changes of stiffness matrixes \mathbf{K}_1 and \mathbf{K}_2 assigned to the meridians α and β . The changes are referred to as $\Delta \mathbf{K}_{1\beta}$, $\Delta \mathbf{K}_{1\gamma}$, $\Delta \mathbf{K}_{2\beta}$, respectively.

According to formulation (14), the correction of the load vector may refer only to the elements \mathbf{Q}_β and \mathbf{Q}_γ . If we take into account while calculating the coefficient (5), their corrected values take the form :

$$\begin{aligned}\mathbf{S}_j^{(i-1)} &= \mathbf{S}_j - \frac{1}{\sqrt{n}} \left(\Delta \mathbf{Q}_\beta^{(i-1)} \cos \beta j \frac{2\pi}{n} + \Delta \mathbf{Q}_\gamma^{(i-1)} \cos \gamma j \frac{2\pi}{n} \right) , \\ \mathbf{T}_j^{(i-1)} &= \mathbf{T}_j - \frac{1}{\sqrt{n}} \left(\Delta \mathbf{Q}_\beta^{(i-1)} \sin \beta j \frac{2\pi}{n} + \Delta \mathbf{Q}_\gamma^{(i-1)} \sin \gamma j \frac{2\pi}{n} \right) ,\end{aligned}\quad (18)$$

where

$$\begin{aligned}\Delta \mathbf{Q}_\beta^{(i-1)} &= \Delta \mathbf{K}_{1\beta} \mathbf{q}_\beta^{(i-1)} + \Delta \mathbf{K}_{2\gamma} \mathbf{q}_\gamma^{(i-1)} , \\ \Delta \mathbf{Q}_\gamma^{(i-1)} &= \Delta \mathbf{K}_{2\beta} \mathbf{q}_\beta^{(i-1)} + \Delta \mathbf{K}_{1\gamma} \mathbf{q}_\gamma^{(i-1)} , \\ \Delta \mathbf{K}_{2\beta} &= \Delta \mathbf{K}_{2\gamma}^T .\end{aligned}\quad (19)$$

When the modification refers to elements placed between several meridians described with the identification matrixes $[\beta]$ and $[\gamma]$, respectively, where the elements of the matrixes $[\beta]$ and $[\gamma]$ are correlated with each other according to the formulation (17), the corrected values of the coefficients $\mathbf{S}_j^{(i-1)}$ and $\mathbf{T}_j^{(i-1)}$ are calculated from the respective formulations:

$$\begin{aligned} \mathbf{S}_j^{(i-1)} &= \mathbf{S}_j - \frac{1}{\sqrt{n}} \left(\sum_{[\beta]} \Delta \mathbf{Q}_\beta^{(i-1)} \cos \beta_j \frac{2\pi}{n} + \sum_{[\gamma]} \Delta \mathbf{Q}_\gamma^{(i-1)} \cos \gamma_j \frac{2\pi}{n} \right), \\ \mathbf{T}_j^{(i-1)} &= \mathbf{T}_j - \frac{1}{\sqrt{n}} \left(\sum_{[\beta]} \Delta \mathbf{Q}_\beta^{(i-1)} \sin \beta_j \frac{2\pi}{n} + \sum_{[\gamma]} \Delta \mathbf{Q}_\gamma^{(i-1)} \sin \gamma_j \frac{2\pi}{n} \right). \end{aligned} \quad (20)$$

C. In the case of a simultaneous modification of the structure consisting in the alteration of the stiffness of the elements overlapping with the meridians as well as the ones placed between the neighbouring meridians, the corrected values of the coefficients $\mathbf{S}_j^{(i-1)}$ and $\mathbf{T}_j^{(i-1)}$ are calculated taking into account the combined corrections described with formulations (16) and (20).

3. EXAMPLES AND NUMERICAL ANALYSES

The numerical calculations have been carried out with the use of an elaborated programme, allowing the analysis of various types of circular-symmetric structures. The suitable stiffness matrices of the original system (its repeatable part) as well as modification matrices of the size $m \times m$ are input to the programme in a form of files obtained as outputs of other programmes basing on the finite element method.

The aim of the calculations was to test the programme, verify the proposed iterative procedure as well as to carry out the analysis of the influence of the selected parameters of the structure on its displacements. Circular-symmetric plane frames, grids as well as spatial trusses have been analysed.

Example 1. Modifications of a plane frame of immovable nodes (a test example)

The example presents the analysis of modification of a plane frame shown in fig.2a.

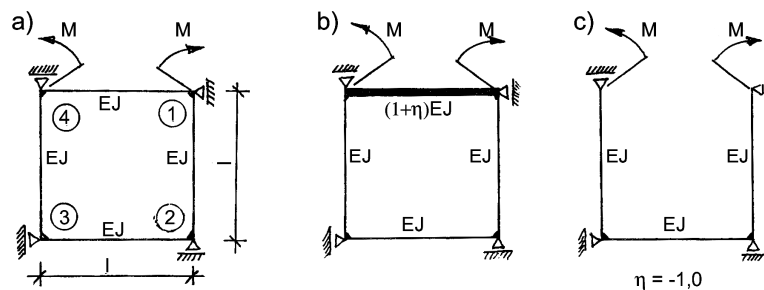

Fig. 2. Static scheme of the frame

a-original frame, b-frame with a strengthened rod 1-4, c-frame with a removed rod 1-4

The nodes may rotate only, so $n=4$, $m=1$.

Two cases of modification have been analysed. The first case refers to the rod strengthening 1-4 (fig.2b) while the other considers to a complete removal of the rod (fig.2c). The analysis of the convergence of the iteration process is presented in fig.3. A satisfying accuracy of the determination of the displacements has been obtained for 6 iterations.

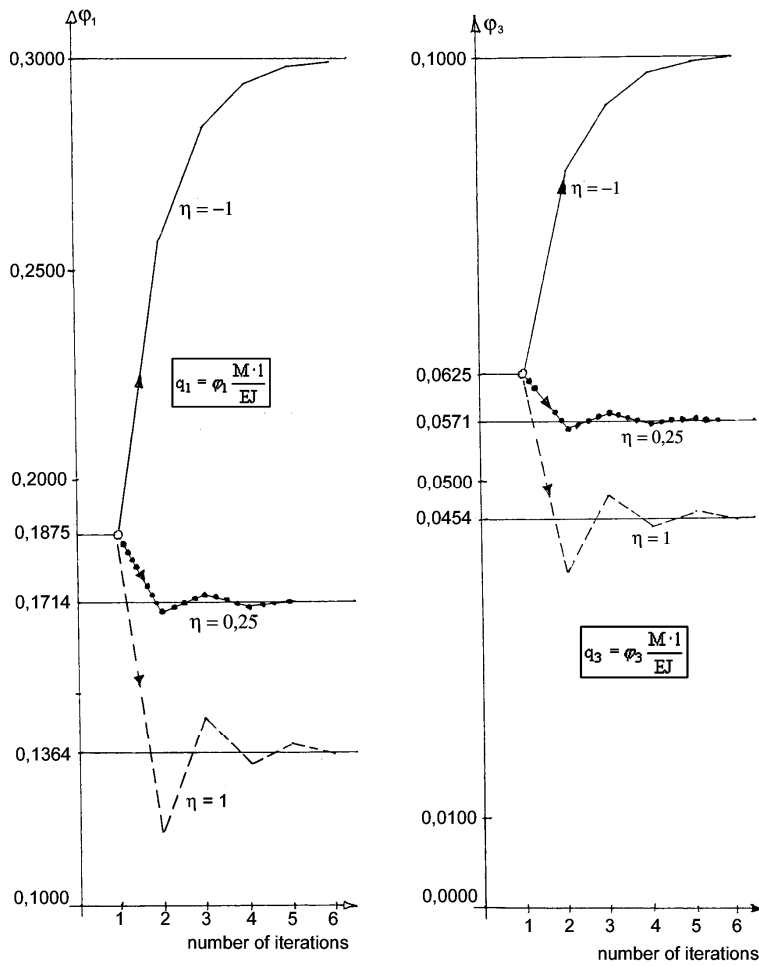

Fig. 3. Relation between the accuracy of determination of displacements in the selected nodes of the frame and the number of iterations.

Example 2. Plane frame of 12 immovable nodes

Various cases of modifications of the plane frame, presented in fig.5a, have been analysed in the example. The nodes of the frame may rotate only, so $n=4$, $m=3$.

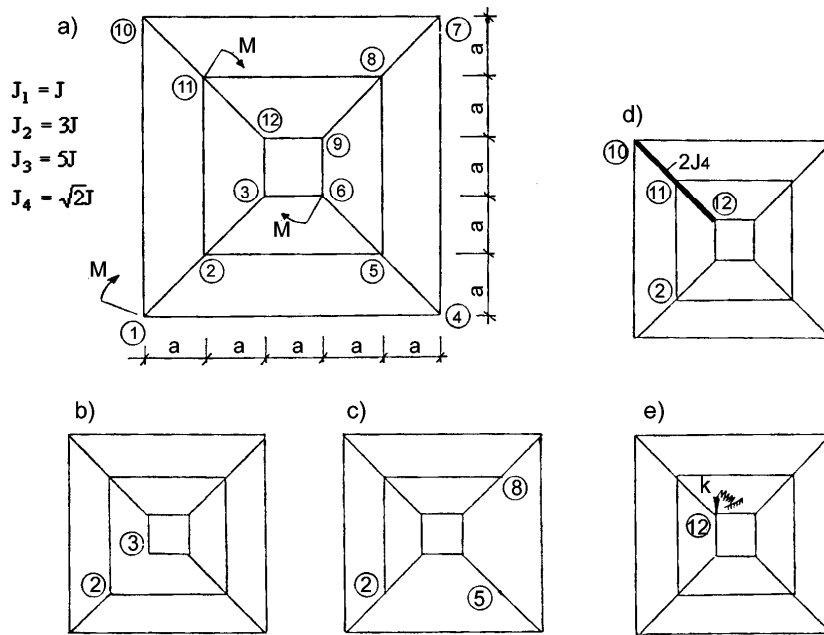

Fig. 5. Static scheme of the frame

a - original frame, b - frame with a removed meridional rod, c - frame with removed parallel rods, d - frame with a strengthened meridional rod, e - frame with additional elastic support in node 12

The analysis of the convergence process for a few variants of modifications is presented in a form of a graph in fig.6. A satisfying convergence of the iteration, with the accuracy $\epsilon = 0.01$, has been obtained for 12 iterations.

The analysis of the influence of the stiffness of the additional elastic support on the rate of iteration is presented in fig.7. For $\kappa = 11 \left(\kappa = 11 \frac{EJ}{a} \right)$ a solution has not been obtained (a divergent process).

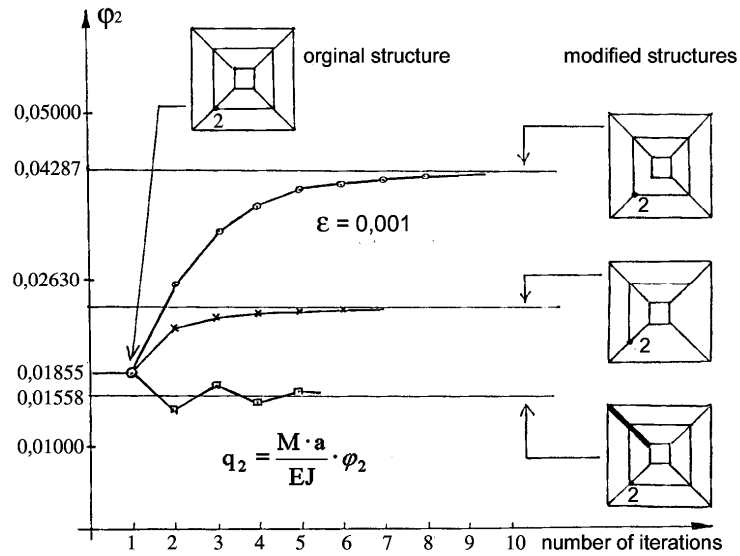

Fig. 6. Influence of various ways of modification on the number of iterations (with the accuracy $\epsilon = 0.001$)

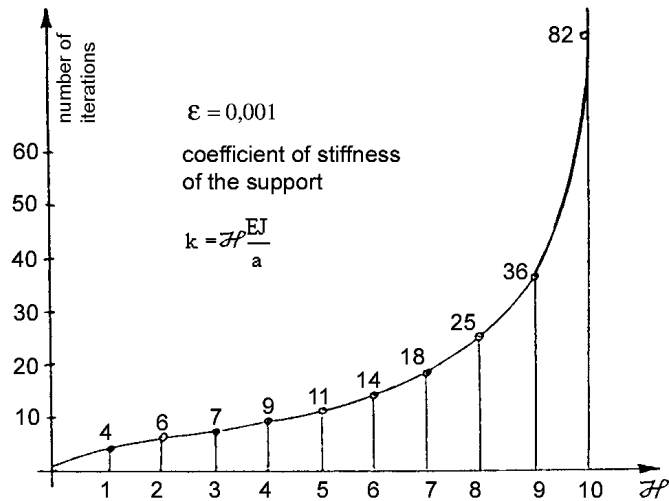

Fig. 7. Relationship between the number of iterations and the stiffness of the additional elastic support.

Example 3. Circular-symmetric grid of rigid nodes.

Various cases of modifications of the grid of a statistic scheme presented in fig.8 are analysed in the example. The grid is loaded with vertical: forces in nodes in the internal ring of the value $P_1 = 20\text{kN}$ and in nodes in the central ring $P_2 = 10\text{kN}$. Since each node has three degrees of freedom, $n=12$, $m.= 6$

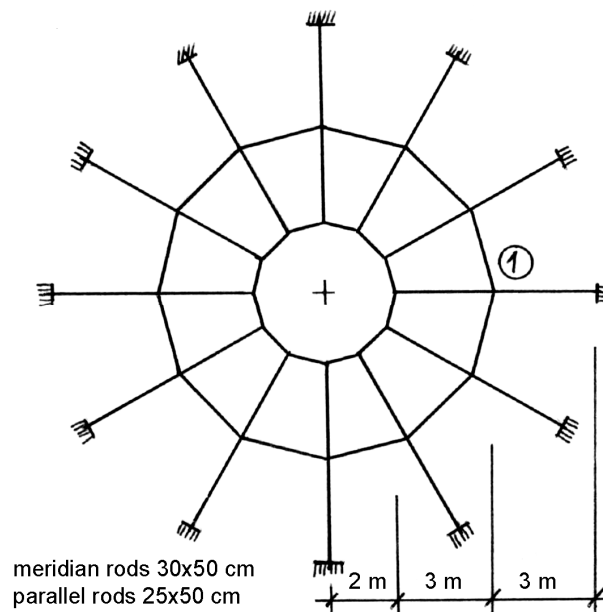

Fig. 8. Static scheme of the grid

Various cases of the grid modifications have been analysed:

- rod removal (fig.9a,b),
- rod strengthening (fig.9c,10a),
- introduction of additional vertical elastic supports (fig.11a).

In the case of a modification according to fig.9, the following numbers of iterations were to be performed to obtain the accuracy $\varepsilon = 0.001$:

- a) 25 – for grid in fig.9a,
- b) 135 – for grid in fig.9b,
- c) 21 – for grid in fig.9c.

For the grid modified according to fig.10a, the number of iterations depends on the parameter of strengthening η , calculated as a relation of the stiffness after strengthening to the original stiffness (fig.10b).

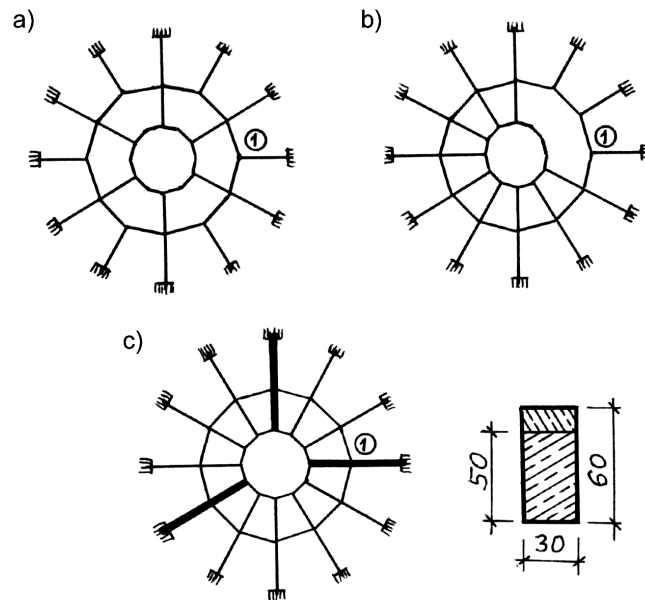
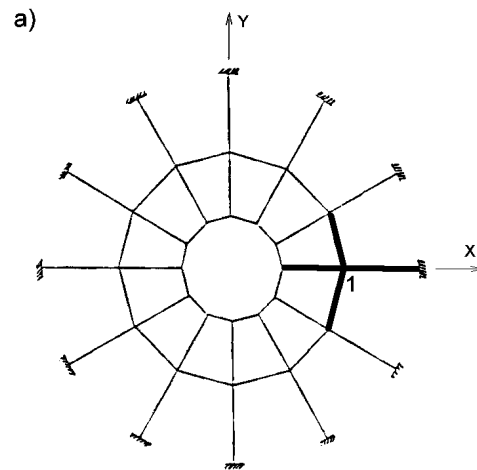

Fig. 9. Static scheme of modified grids
 a, b – rods removed; c – rod strengthened



strengthening

$$EJ = \eta EJ^0, \quad GJ_s = \eta GJ_s^0$$

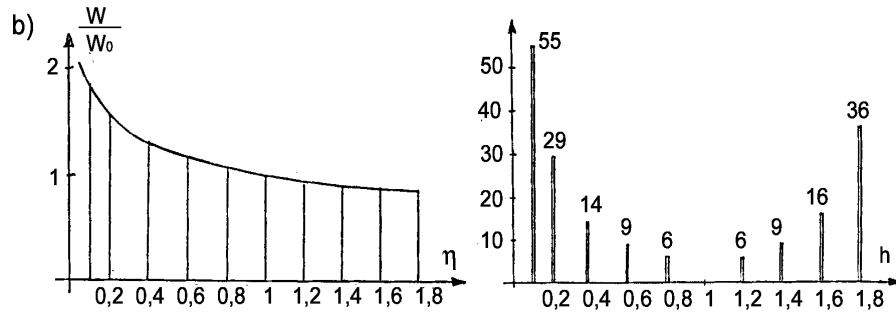

Fig. 10 Grid with strengthened (weakening) rods
 a – static scheme; b – relationship between the number of iterations and a relative shift in the vertical displacement of nod 1 and the strengthening parameter

The number of iterations depends also on the stiffness of additional elastic supports (fig.11b).

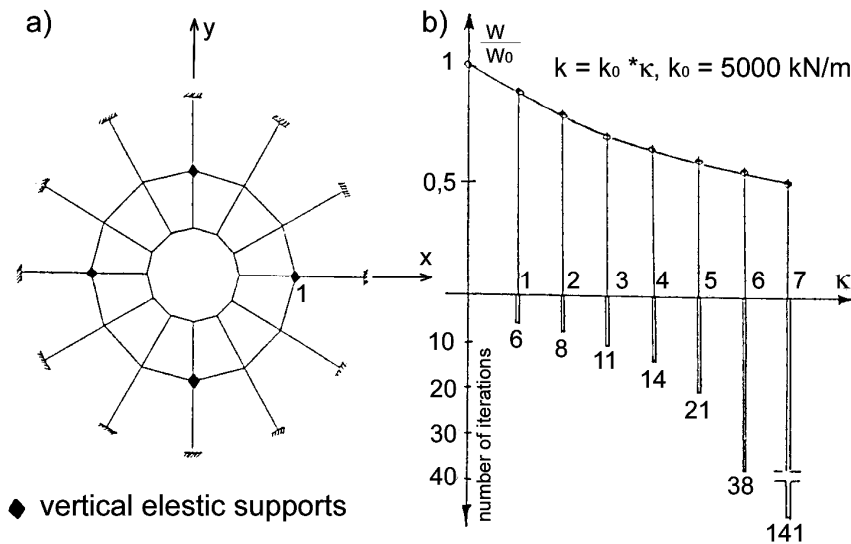

Fig. 11. Grid with additional elastic supports:
 a – static scheme; b – relationship between the number of iterations and a relative shift in the vertical displacement of node 1 and the stiffness of additional elastic supports

Example 4. Spatial truss

In the example various cases of modifications of the truss, whose static scheme is presented in fig.12, have been analysed. All the rods of the truss before the modification are of identical stiffness EA . The truss is loaded with vertical forces $P = 1$ in the top nodes.

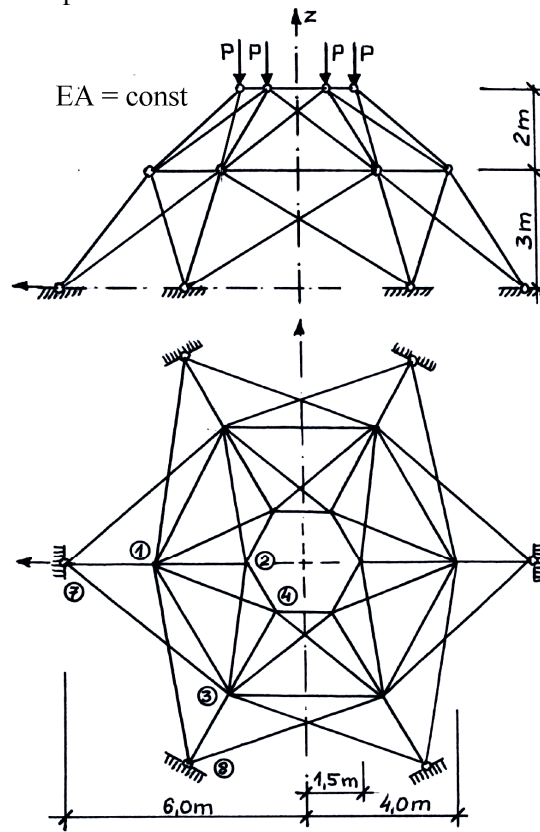

Fig. 12. Static scheme of the truss

Depending on the way of modification (fig.13), it has been necessary to perform a different number of iterations to obtain the accuracy $\varepsilon = 0.001$. The iteration process while determining the vertical displacement of node 4 is presented in fig.14.

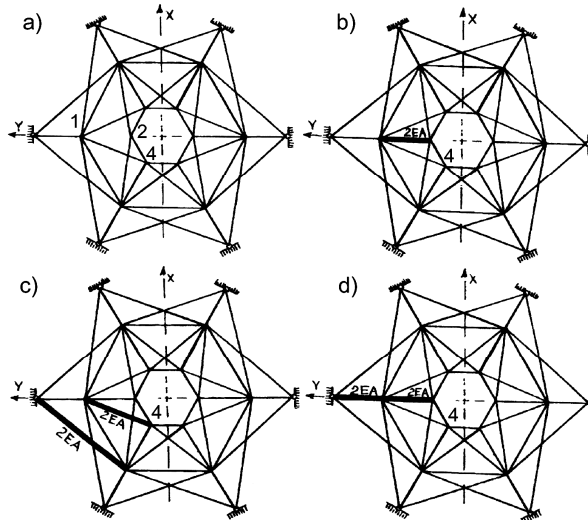

Fig. 13. Static scheme of modified trusses:
 a – rods 1 – 2 removed; b,c,d – rods strengthened

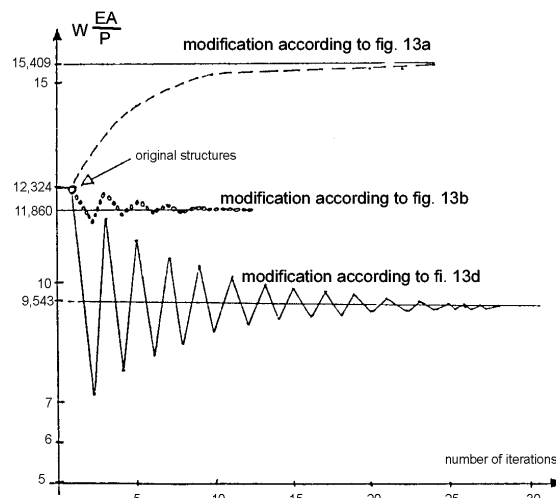

Fig. 14. Truss with reinforced rods: a – static scheme; b – relationship between the method convergence and the way of modification

In case of a strengthened (weakened) truss, according to the scheme presented in fig.15a, the number of iterations depends on the strengthening parameter η . The relationship is presented in fig.15b.

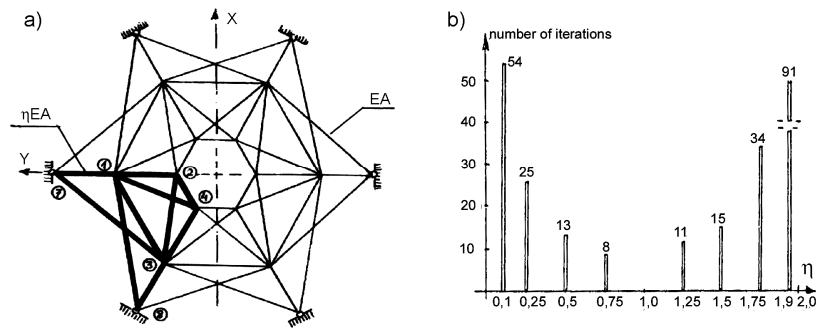

Fig. 15. Truss with strengthened (weakened) rods:
a – static scheme; b – relation between the number of iterations
and the parameter of strengthening

The number of iterations also depends to a large extent on the stiffness of the additional elastic supports (fig.16).

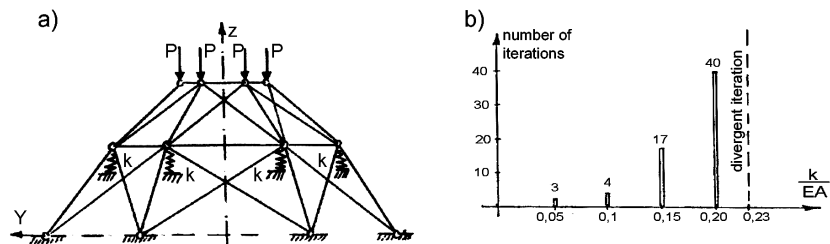

Fig. 16. Truss with additional elastic supports:
a – static scheme; b – relation between the number of iterations and the
stiffness of additional elastic supports

4. SUMMARY

Analyses of a lot of modified structures originally circular-symmetric have been carried out. Only selected results of the analyses have been presented in the paper. The results obtained indicate that the iterative method proposed together with the application of spectral properties of cyclic and quasi-cyclic matrices is effective in many cases. Although the algorithm itself is not unconditionally convergent, it often provides accurate solutions even with considerable changes in the original structure. Operating on matrices considerably smaller than full matrices describing the structure compensates considerably for the necessity of performing a greater number of iterations than when applying other methods of modifications.

REFERENCES

1. Dinkiewicz S.Z.: Calculation of cyclic structures. Spectral method, Moscow, Strojizdat 1977 (in Russian).
2. Kuczma M.S., Demkowicz L.: An adaptive algorithm for unilateral viscoelastic contact problems for beams and plates, *Comput. Methods Appl. Mech. Engrg.* 101 (1992) 183-196.
3. Pryputniewicz S., Numerical Analysis of circular-symmetric suspension grids, VI Conference " Computer methods in mechanics", Białystok (1983), vol.II 95-100 (in Polish).
4. Pryputniewicz S., The analysis of interaction between a circular-symmetric suspension roof and a supportive structure. II Scientific Conference "Suspension Structures and Shells", Rydzyna (1983) (in Polish).
5. Świszczowski S. ,Modification methods in the analysis of elastic structures, *Arch. Inż. Łąd.*, 25, 1 (1979) 11-20 (in Polish).
6. Świtka R., On the use of discrete Fourier series in structural mechanics on the example of polar grates, *Zeszyty Naukowe Politechniki Poznańskiej. Budownictwo Lądowe* 25, Poznań (1980) (in Polish).
7. Świtka R., Husiar B., Discrete analysis of rheological models, *Mech. Teor. Stos.* 22 (1984) 209-233 (in Polish).
8. Świtka R, A discretization method of rheological problems, *Proc. Conf. Rheology of Wood*, Poznań (1982) 211-218 (in Polish).

**ITERACYJNA METODA OBLICZANIA MODYFIKOWANYCH
KONSTRUKCJI PIERWOTNIE KOŁOWO-SYMETRYCZNYCH****Streszczenie**

W pracy zaproponowano iteracyjny sposób obliczania modyfikowanych konstrukcji pierwotnie kołowo-symetrycznych, w którym na każdym kroku iteracji korzysta się z cyklicznej (lub quasicyklicznej) macierzy sztywności konstrukcji pierwotnej. Wykonano obliczenia wielu modyfikowanych układów znacznie różniących się od kołowo-symetrycznych (brak niektórych elementów, wzmocnienia, dodatkowe podpory). Uzyskane wyniki wskazują na to, że chociaż algorytm nie jest bezwarunkowo zbieżny to nawet przy znacznych zmianach w konstrukcji pierwotnej uzyskuje się często dokładne rozwiązania. Działanie na macierzach znacznie mniejszych od pełnych macierzy opisujących układ znacząco rekompensuje konieczność wykonania większej liczby iteracji niż przy korzystaniu z innych metod.