

STRESS EQUATIONS FOR ADHESIVE IN TWO-DIMENSIONAL ADHESIVELY BONDED JOINTS

Piotr RAPP¹

Poznań University of Technology, Poland

Abstract

The subject of this paper is formulation of shear stress equations for plane two-dimensional adhesive layers present in adhesively bonded joints. The adherends are assumed to have the same thickness and be made of an isotropic material. The shape of the adherends in the joint plane is arbitrary. The adhesive joint can be subjected to a shear stress arbitrarily distributed on the adherends surfaces as well as normal and shear stresses arbitrarily distributed along the adherends edges. A set of two partial differential equations of the second order with shear stresses in the adhesive as unknowns has been formulated. For a particular case of rectangular joints a set of 12 base functions has been derived; their appropriate linear combinations uniquely define shear stresses in the adhesive for a joint loaded arbitrarily by a set of axial forces, bending moments and shear forces.

Keywords: adhesively bonded joints, analytical models, two dimensional shear stresses in adhesive, isotropy, linear elasticity

1. INTRODUCTION

Analytical methods used to determine stresses in adhesive joints were first presented by Volkersen in [16], where he formulated and solved a one-dimensional ordinary differential equation for a shear stress in a lap joint loaded axially. Later, up till now many further papers appeared where analytical models of adhesive joints were discussed. However, the majority of them concerns particular generalizations of one-dimensional cases with axial loading.

¹ Corresponding author: Poznań University of Technology, 5 M. Skłodowskiej-Curie Sq. 60-965 Poznań, Poland, e-mail: piotr.rapp@put.poznan.pl, tel .+48616652094

An analytical description of an adhesive joint becomes much more complicated if the joint is subjected to a plane loading set. In these cases two-dimensional models in the joint plane should be formulated.

First analytical models of a lap joint in a two-dimensional plane XY of the joint, loaded axially by a constant stress in the direction X have been proposed in [1, 2]. It was assumed, that the joint was plane, the adherends had constant thickness and were made of isotropic materials. In the analysis it was further assumed that the shear stress τ_{xy} in the adherends was zero. For each adherend a set of two partial differential equations of the second order with constant coefficients in terms of normal stresses σ_x and σ_y in adherends was formulated. The shear stress in the adhesive, which represents a loading acting on the adherends was determined from simplified equilibrium equations of the adherends in the plane stress state with the shear stress τ_{xy} neglected. Introducing further simplifications, i.e. neglecting the coupling between the stresses σ_x and σ_y , the set of partial differential equations was transformed to two independent ordinary differential equations for which analytical solutions were presented. Taking into account the Poisson's ratio it was shown that the adherends loaded in the X direction exhibit deformation in the Y direction, too. The consequence of this fact is the existence of shear stresses in the adhesive - τ_x in the loading direction and τ_y in the transverse direction.

A more precise two-dimensional model of an adhesive joint based on the equations of the theory of elasticity was given in [8, 9]. A rectangular joint between isotropic and orthotropic adherends was considered. It was assumed that the isotropic adherend was loaded on its edges by constant normal stresses in X and Y directions as well as by a self-balanced set of shear stresses, while the orthotropic adherend was not loaded. The analysis was subdivided into two stages: two-directional loading by the normal stresses and the shear stress loading.

For the case of the two-directional loading by the normal stresses the same simplifying assumptions were made and analogous partial differential equations to those from [1, 2] were obtained. Due to the presence of simultaneous action of loading in two directions the partial differential equations were not simplified to the ordinary form. The set of equations was solved using Fourier series expansions. The shear stresses τ_x and τ_y in the adhesive were determined from the simplified equilibrium equations with the shear stress τ_{xy} in the adherends neglected. For the case of the shear stress loading acting on the joint simplified equilibrium equations with the neglected normal stresses σ_x and σ_y in the adherends were used. The problem was described by a differential equation of the second order

in terms of the shear stress τ_{xy} in the orthotropic adherend. This equation was solved using Fourier series expansion.

Earlier, in [6] and [7] rectangular joints and joints forming an infinite band loaded by normal and shear stresses were analyzed in a similar way.

Analytical models presented in the literature contain simplifications with some stress components neglected in the equilibrium equations for the adherends, partial neglecting of coupling between the variables and particular simple cases of loading only taken into account.

The current overview of analytical models for adhesive joints and their comparison can be found in [3, 13, 14]. However, there is no mention of equations for shear stresses in adhesive for two-dimensional joints.

A general model of adhesive joints for anisotropic materials in the framework of the plane theory of elasticity, free from the above mentioned simplifications, was given in [10, 11], and a model for an orthotropic material in terms of displacements - in [10, 12]. The problem was expressed by four partial differential equations of the second order with adherends displacements taken as the unknowns.

The purpose of the present paper is to describe a particular case, for which those four equations in displacements can be transformed to two partial differential equations of the second order with shear stresses in the joint as the unknowns.

2. MODEL OF TWO-DIMENSIONAL ADHESIVE JOINT

The subject of this paper are adhesive joints made of two plane adherends bonded by an adhesive. It is assumed that the plane elements are thin and have constant, but in general different thickness values g_1 and g_2 . The adherends can be made of the same or two different isotropic materials. The adhesive between the adherends is thin and has a constant thickness t .

The adhesive joint is modelled as a plane two-dimensional system parallel to the plane OXY in the orthogonal set of co-ordinates OXYZ. The projections of the adherends and the adhesive to the plane have the same shape which may be arbitrary. The adhesive joint is loaded by forces parallel to the plane OXY which are distributed on surfaces and edges of the adherends (Fig. 1).

It is assumed that effects of bending of the adherends are secondary and can be neglected. It is further assumed, that stresses across the adherend thickness are constant. Hence, the plane stress states parallel to the plane OXY are formed. Thus, the adherends are considered as the plane stress elements parallel to the plane OXY.

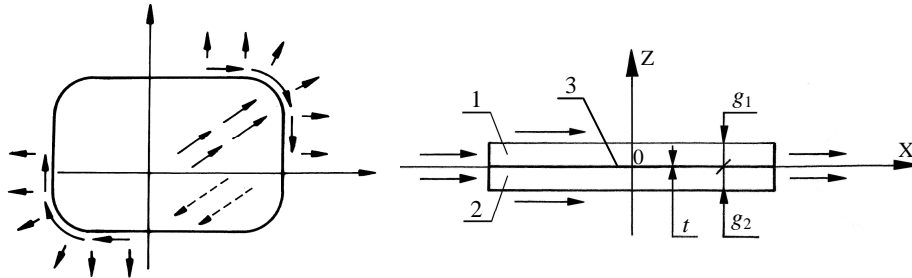

Fig. 1. Layout of an adhesive joint. $\tilde{1}$ adherend 1, $\tilde{2}$ adherend 2, $\tilde{3}$ adhesive

The adhesive is modelled as a linearly elastic medium with the stresses $\tau_x = \tau_x(x, y)$, $\tau_y = \tau_y(x, y)$ tangent to the joint mid-plane. It is assumed that the functions τ_x and τ_y are C^2 -continuous in terms of partial derivatives with respect to the variables x, y . The stresses in the adhesive are constant across their thickness. Due to the action of the shear stresses τ_x and τ_y in the adhesive a shear deformation is observed and it leads in turn to relative displacements of adhesive layers in the direction tangent to the mid-plane of the joint.

Displacements of the adherends 1 and 2 are given by the functions $u_1 = u_1(x, y)$ and $u_2 = u_2(x, y)$ in the direction X and the functions $v_1 = v_1(x, y)$ and $v_2 = v_2(x, y)$ in the direction Y. It is assumed that the functions u_1, u_2, v_1 and v_2 are C^2 -continuous in terms of partial derivatives with respect to the variables x, y .

The distributed loading on the external surfaces of the adherends 1 and 2 is expressed in terms of components parallel to the axes X and Y denoted by $q_{1x} = q_{1x}(x, y)$, $q_{2x} = q_{2x}(x, y)$ and $q_{1y} = q_{1y}(x, y)$, $q_{2y} = q_{2y}(x, y)$. The loading is positive when its orientation coincides with that of the axis X or Y.

3. CONSTITUTIVE EQUATIONS FOR THE ADHERENDS

It is assumed that the adherends 1 and 2 can be made of two different isotropic materials, for which the constitutive equations take the form of the generalised Hooke's law

$$\varepsilon_{kx} = \frac{1}{E_k} (\sigma_{kx} - \nu_k \sigma_{ky}), \quad (1.1)$$

$$\varepsilon_{ky} = \frac{1}{E_k} (\sigma_{ky} - \nu_k \sigma_{kx}) \quad (1.2)$$

$$\gamma_{kxy} = \frac{1}{G_k} \tau_{kxy}, \quad (1.3)$$

where E_k , G_k stand for Young's and shear moduli, respectively, ν_k is the Poisson's ratio for the adherend material k ($k = 1, 2$). The moduli E_k , G_k and ν_k are inter-related by $E_k = 2(1 + \nu_k)G_k$. Having solved the set of Eqs. (1.1) - (1.3) in terms of stresses and taking into account the Cauchy geometric equations

$$\varepsilon_{kx} = \frac{\partial u_k}{\partial x}, \quad \varepsilon_{ky} = \frac{\partial v_k}{\partial y}, \quad \gamma_{kxy} = \frac{\partial u_k}{\partial y} + \frac{\partial v_k}{\partial x}$$

one gets the constitutive relations in the following form

$$\sigma_{kx} = \frac{E_k}{1 - \nu_k^2} \frac{\partial u_k}{\partial x} + \frac{\nu_k E_k}{1 - \nu_k^2} \frac{\partial v_k}{\partial y}, \quad (2.1)$$

$$\sigma_{ky} = \frac{\nu_k E_k}{1 - \nu_k^2} \frac{\partial u_k}{\partial x} + \frac{E_k}{1 - \nu_k^2} \frac{\partial v_k}{\partial y}, \quad (2.2)$$

$$\tau_{kxy} = \frac{E_k}{2(1 + \nu_k)} \left(\frac{\partial u_k}{\partial y} + \frac{\partial v_k}{\partial x} \right). \quad (2.3)$$

4. CONSTITUTIVE EQUATIONS FOR THE ADHESIVE

It is assumed that the adhesive is made from a linearly elastic material with the shear modulus G_s . Due to the action of the shear stresses τ_x and τ_y in the adhesive a shear deformation occurs resulting in a relative displacement of the adherends in the directions parallel to the mid-plane of the adhesive. The shear stresses τ_x and τ_y in the adhesive are expressed in terms of the displacements of the adherends u_1, u_2, v_1, v_2 by the relations

$$\tau_x = \frac{G_s}{t} (u_1 - u_2), \quad \tau_y = \frac{G_s}{t} (v_1 - v_2). \quad (3)$$

5. STRESS EQUATIONS FOR THE ADHESIVE

The equations with the unknown displacements u_1, u_2, v_1, v_2 derived in [10, 11, 12] for isotropic materials take the form

$$\left(1 + \frac{1+\nu_1}{1-\nu_1}\right) \frac{\partial^2 u_1}{\partial x^2} + \frac{\partial^2 u_1}{\partial y^2} + \frac{1+\nu_1}{1-\nu_1} \frac{\partial^2 v_1}{\partial x \partial y} - \frac{1}{tg_1} \frac{G_s}{G_1} (u_1 - u_2) + \frac{q_{1x}}{g_1 G_1} = 0, \quad (4.1)$$

$$\left(1 + \frac{1+\nu_2}{1-\nu_2}\right) \frac{\partial^2 u_2}{\partial x^2} + \frac{\partial^2 u_2}{\partial y^2} + \frac{1+\nu_2}{1-\nu_2} \frac{\partial^2 v_2}{\partial x \partial y} + \frac{1}{tg_2} \frac{G_s}{G_2} (u_1 - u_2) + \frac{q_{2x}}{g_2 G_2} = 0, \quad (4.2)$$

$$\frac{\partial^2 v_1}{\partial x^2} + \left(1 + \frac{1+\nu_1}{1-\nu_1}\right) \frac{\partial^2 v_1}{\partial y^2} + \frac{1+\nu_1}{1-\nu_1} \frac{\partial^2 u_1}{\partial x \partial y} - \frac{1}{tg_1} \frac{G_s}{G_1} (v_1 - v_2) + \frac{q_{1y}}{g_1 G_1} = 0, \quad (4.3)$$

$$\frac{\partial^2 v_2}{\partial x^2} + \left(1 + \frac{1+\nu_2}{1-\nu_2}\right) \frac{\partial^2 v_2}{\partial y^2} + \frac{1+\nu_2}{1-\nu_2} \frac{\partial^2 u_2}{\partial x \partial y} + \frac{1}{tg_2} \frac{G_s}{G_2} (v_1 - v_2) + \frac{q_{2y}}{g_2 G_2} = 0. \quad (4.4)$$

Derivation of general differential equations for the stresses in the adhesive should involve the elimination of the displacements u_1 , u_2 , v_1 , v_2 from the displacement Eqs. (4.1) – (4.4), where the expressions $u_1 - u_2$ and $v_1 - v_2$ should be replaced by the relations (3). The elimination of the functions u_1 , u_2 , v_1 , v_2 involves algebraic operations including numerous differentiations. As a result one gets complicated expressions and the order of the equations is artificially increased. Additionally, one has to formulate boundary conditions, which represent differential identities yielding from the operations carried out, which usually do not possess any physical interpretation. Due to these facts general equations for the stresses in the adhesive were not formulated because they would have had an order higher than two and would have been much more complicated than the equations derived in the present paper.

In some particular cases derivation of the stress equations for the adhesive is simple to carry out by subtracting sides of displacements equations in order to get equations depending only on the displacements differences $u_1 - u_2$ and $v_1 - v_2$. In such equations the constitutive relations for the adhesive can be used directly and they yield the equations for the stresses in the adhesive. Such an approach does not raise the order of equations and does not require any additional boundary conditions.

This procedure can be used for two different isotropic materials, however it must be assumed that the Poisson's ratios are identical for both materials.

Subtracting the sides of the Eq. (4.2) from the Eq. (4.1) and the Eq. (4.4) from the Eq. (4.3) the description in displacements (3), (4.1) – (4.4) is transformed into a description in stresses. However, the equality must be maintained

$$\frac{1+\nu_1}{1-\nu_1} = \frac{1+\nu_2}{1-\nu_2}. \quad (5)$$

Hence, assuming the equivalent Poisson's ratio ν instead of ν_1 and ν_2 , for example $\nu = 0,5(\nu_1 + \nu_2)$, and denoting

$$\alpha = \frac{1+\nu}{1-\nu}, \quad (6)$$

and then subtracting the sides of the Eq. (4.2) from (4.1) and the Eq. (4.4) from (4.3) one gets

$$(1+\alpha)\frac{\partial^2(u_1-u_2)}{\partial x^2} + \frac{\partial^2(u_1-u_2)}{\partial y^2} + \alpha\frac{\partial^2(u_1-u_2)}{\partial x\partial y} - k^2(u_1-u_2) + \frac{q_{1x}}{g_1G_1} - \frac{q_{2x}}{g_2G_2} = 0, \quad (7.1)$$

$$\frac{\partial^2(u_1-u_2)}{\partial x^2} + (1+\alpha)\frac{\partial^2(u_1-u_2)}{\partial y^2} + \alpha\frac{\partial^2(u_1-u_2)}{\partial x\partial y} - k^2(u_1-u_2) + \frac{q_{1y}}{g_1G_1} - \frac{q_{2y}}{g_2G_2} = 0, \quad (7.2)$$

where

$$k^2 = \frac{G_s}{t} \left(\frac{1}{g_1G_1} + \frac{1}{g_2G_2} \right) = \frac{2(1+\nu)G_s}{t} \left(\frac{1}{g_1E_1} + \frac{1}{g_2E_2} \right). \quad (8)$$

Taking advantage of the relations (3), displacements can be eliminated from the Eqs. (7.1) – (7.2) and the following stress equations is obtained

$$(1+\alpha)\frac{\partial^2\tau_x}{\partial x^2} + \frac{\partial^2\tau_x}{\partial y^2} + \alpha\frac{\partial^2\tau_x}{\partial x\partial y} - k^2\tau_x + \frac{G_s}{t} \left(\frac{q_{1x}}{g_1G_1} - \frac{q_{2x}}{g_2G_2} \right) = 0, \quad (9.1)$$

$$\frac{\partial^2\tau_y}{\partial x^2} + (1+\alpha)\frac{\partial^2\tau_y}{\partial y^2} + \alpha\frac{\partial^2\tau_y}{\partial x\partial y} - k^2\tau_y + \frac{G_s}{t} \left(\frac{q_{1y}}{g_1G_1} - \frac{q_{2y}}{g_2G_2} \right) = 0. \quad (9.2)$$

The characteristic form $A(\xi_x, \xi_y)$ of the main part of the set of Eqs. (9.1)–(9.2) takes the form:

$$A(\xi_x, \xi_y) = \begin{vmatrix} (1+\alpha)\xi_x^2 + \xi_y^2 & \alpha\xi_x\xi_y \\ \alpha\xi_x\xi_y & \xi_x^2 + (1+\alpha)\xi_y^2 \end{vmatrix} = (1+\alpha)(\xi_x^2 + \xi_y^2)^2.$$

Thus, this characteristic form $A(\xi_x, \xi_y)$ is positively definite and the set (9.1)–(9.2) is elliptic.

6. BOUNDARY CONDITIONS

The adherends 1 and 2 are limited by circumferential edge surfaces perpendicular to the plane OXY. The width of this circumferential surface is equal to the adherend thickness. Let p_{kx} and p_{ky} ($k = 1, 2$) denote the stresses acting on the edge surfaces of the adherend k . It is assumed that the stresses p_{kx} and p_{ky} are parallel to the axes X and Y, respectively and that they are constant across the adherend thickness. These stresses are treated as imposed external loading on the edges of the adherends in the plane parallel to the plane OXY.

The boundary conditions expressed in displacements derived in [10, 12] for isotropic materials take the form

$$\left(\frac{\partial u_1}{\partial x} + \nu_1 \frac{\partial v_1}{\partial y}\right) \cdot l + \frac{1-\nu_1}{2} \left(\frac{\partial u_1}{\partial y} + \frac{\partial v_1}{\partial x}\right) \cdot m = \frac{1-\nu_1^2}{E_1} p_{1x}, \quad (10.1)$$

$$\left(\frac{\partial u_2}{\partial x} + \nu_2 \frac{\partial v_2}{\partial y}\right) \cdot l + \frac{1-\nu_2}{2} \left(\frac{\partial u_2}{\partial y} + \frac{\partial v_2}{\partial x}\right) \cdot m = \frac{1-\nu_2^2}{E_2} p_{2x}, \quad (10.2)$$

$$\frac{1-\nu_1}{2} \left(\frac{\partial u_1}{\partial y} + \frac{\partial v_1}{\partial x}\right) \cdot l + \left(\nu_1 \frac{\partial u_1}{\partial x} + \frac{\partial v_1}{\partial y}\right) \cdot m = \frac{1-\nu_1^2}{E_1} p_{1y}, \quad (10.3)$$

$$\frac{1-\nu_2}{2} \left(\frac{\partial u_2}{\partial y} + \frac{\partial v_2}{\partial x}\right) \cdot l + \left(\nu_2 \frac{\partial u_2}{\partial x} + \frac{\partial v_2}{\partial y}\right) \cdot m = \frac{1-\nu_2^2}{E_2} p_{2y}, \quad (10.4)$$

where l and m are direction cosines of the normal to the edge of the adherend 1 or 2.

The equivalent Poisson's ratio ν is substituted by the Eqs. (10.1) - (10.4) instead of the Poisson's ratios ν_1 and ν_2 . Subtracting the Eq. (10.2) from (10.1) and the Eq. (10.4) from (10.3) yields

$$\begin{aligned} & \left(\frac{\partial(u_1 - u_2)}{\partial x} + \nu \frac{\partial(v_1 - v_2)}{\partial y}\right) \cdot l + \frac{1-\nu}{2} \left(\frac{\partial(u_1 - u_2)}{\partial y} + \frac{\partial(v_1 - v_2)}{\partial x}\right) \cdot m = \\ & = (1-\nu^2) \left(\frac{p_{1x}}{E_1} - \frac{p_{2x}}{E_2}\right) \end{aligned} \quad (11)$$

$$\begin{aligned} & \frac{1-\nu}{2} \left(\frac{\partial(u_1 - u_2)}{\partial y} + \frac{\partial(v_1 - v_2)}{\partial x} \right) \cdot l + \left(\nu \frac{\partial(u_1 - u_2)}{\partial x} + \frac{\partial(v_1 - v_2)}{\partial y} \right) \cdot m = \\ & = (1-\nu^2) \left(\frac{p_{1y}}{E_1} - \frac{p_{2y}}{E_2} \right). \end{aligned} \quad (12)$$

Taking advantage of the relation (3), displacements can be eliminated from the Eqs. (11) and (12). Having done these operations the boundary conditions in stresses are as follows:

$$\left(\frac{\partial \tau_x}{\partial x} + \nu \frac{\partial \tau_y}{\partial y} \right) \cdot l + \frac{1-\nu}{2} \left(\frac{\partial \tau_x}{\partial y} + \frac{\partial \tau_y}{\partial x} \right) \cdot m = \frac{(1-\nu^2)G_s}{t} \left(\frac{p_{1x}}{E_1} - \frac{p_{2x}}{E_2} \right), \quad (13.1)$$

$$\frac{1-\nu}{2} \left(\frac{\partial \tau_x}{\partial y} + \frac{\partial \tau_y}{\partial x} \right) \cdot l + \left(\nu \frac{\partial \tau_x}{\partial x} + \frac{\partial \tau_y}{\partial y} \right) \cdot m = \frac{(1-\nu^2)G_s}{t} \left(\frac{p_{1y}}{E_1} - \frac{p_{2y}}{E_2} \right). \quad (13.2)$$

In the stress formulation (9.1) - (9.2) the boundary conditions (13.1) - (13.2) are sufficient for a unique derivation of the shear stresses τ_x and τ_y .

7. VERIFICATION OF THE STRESS EQUATIONS

If the adherends are made from the same material then $E_1 = E_2$ and $\nu = \nu_1 = \nu_2$. In this case, within the scope of the assumptions made, the Eqs. (9.1) - (9.2) yield the stresses in the adhesive exactly. If the adherends are made of two materials with differing Poisson's ratios $\nu_1 \neq \nu_2$, then the Eqs. (9.1) - (9.2), including the equivalent Poisson's ratio ν , describe the stresses in the adhesive in an approximate way.

The solution of the formulation in displacements (3), (4.1) - (4.4) can be used to compare results and assess the accuracy of the stress Eqs. (9.1) - (9.2), with the equivalent Poisson's ratio ν adopted.

It can be stated [10] that for $\nu_1 \neq \nu_2$ solutions of the stress Eqs. (9.1) - (9.2), with the equivalent Poisson's ratio $\nu = 0,5(\nu_1 + \nu_2)$ are good approximations of the exact solutions. In the light of small differences between ν_1 and ν_2 a relative error in resultant stresses in the adhesive is generally about 1% of their maximal values. Calculations carried out for various values of the Poisson's ratio from the range $0 \leq \nu \leq 0,5$ indicate, that the solutions of the Eqs. (9.1) - (9.2) are approximately linear functions of the equivalent Poisson's ratio ν . It means, that the solution of the stress Eqs. (9.1) - (9.2) with the equivalent Poisson's ratio $\nu = 0,5(\nu_1 + \nu_2)$ is approximately equal to the arithmetic mean from the solutions obtained separately for $\nu = \nu_1$ and $\nu = \nu_2$.

8. RECTANGULAR JOINTS UNDER COMPLEX LOADING

It is assumed that the loading q_{1x} , q_{2x} , q_{1y} , q_{2y} on the adherends surfaces is zero. Thus, the Eqs. (9.1) – (9.2) take the form

$$(1 + \alpha) \frac{\partial^2 \tau_x}{\partial x^2} + \frac{\partial^2 \tau_x}{\partial y^2} + \alpha \frac{\partial^2 \tau_y}{\partial x \partial y} - k^2 \tau_x = 0, \quad (14.1)$$

$$\frac{\partial^2 \tau_y}{\partial x^2} + (1 + \alpha) \frac{\partial^2 \tau_y}{\partial y^2} + \alpha \frac{\partial^2 \tau_x}{\partial x \partial y} - k^2 \tau_y = 0. \quad (14.2)$$

In this case any loading present at the adherends edges is included in the boundary conditions.

For practical purposes a particular group of loading sets can be distinguished by the assumption that the adherend edges are loaded by the stresses resulting from the axial forces N , bending moments M and shear forces T , according to Fig. 2. It is assumed that due to the action of these forces on the adherend edges uniformly distributed normal stresses, linearly varying normal stresses and parabolic shear stresses, respectively, are formed (Fig. 3).

Boundary conditions (13.1) - (13.2) for a rectangle can be given in the form – upper horizontal edge ($l = 0$, $m = 1$)

$$\frac{\partial \tau_x}{\partial y} + \frac{\partial \tau_y}{\partial x} = T_g(x), \quad \nu \frac{\partial \tau_x}{\partial x} + \frac{\partial \tau_y}{\partial y} = N_g(x), \quad (15)$$

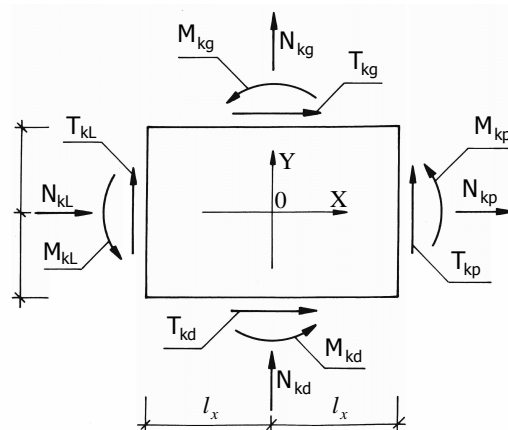

Fig. 2. Concentrated loading on edges of adherends ($k = 1, 2$)

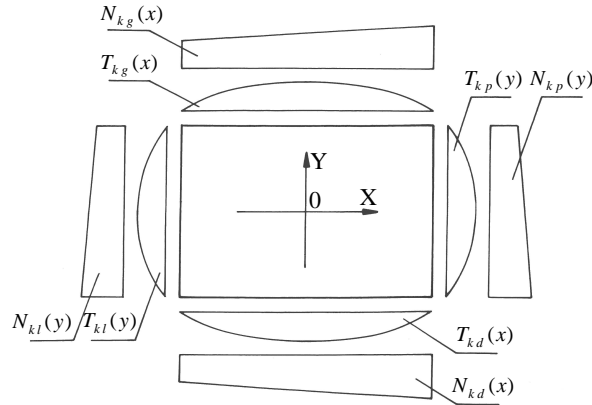

Fig. 3. Schematic graphs of the functions $T_{kg}, N_{kg}, T_{kp}, N_{kp}, T_{kd}, N_{kd}, T_{kl}, N_{kl}$

– right vertical edge ($l = 1, m = 0$)

$$\frac{\partial \tau_x}{\partial y} + \frac{\partial \tau_y}{\partial x} = T_p(y), \quad \frac{\partial \tau_x}{\partial x} + \nu \frac{\partial \tau_y}{\partial y} = N_p(y), \quad (16)$$

– lower horizontal edge ($l = 0, m = -1$)

$$\frac{\partial \tau_x}{\partial y} + \frac{\partial \tau_y}{\partial x} = -T_d(x), \quad \nu \frac{\partial \tau_x}{\partial x} + \frac{\partial \tau_y}{\partial y} = -N_d(x), \quad (17)$$

– left vertical edge ($l = -1, m = 0$)

$$\frac{\partial \tau_x}{\partial y} + \frac{\partial \tau_y}{\partial x} = -T_l(y), \quad \frac{\partial \tau_x}{\partial x} + \nu \frac{\partial \tau_y}{\partial y} = -N_l(y), \quad (18)$$

where

$$N_g(x) = \frac{3G_s(1-\nu^2)}{2tl_x^3} x \cdot m_g + \frac{G_s(1-\nu^2)}{2tl_x} \cdot n_g, \quad (19.1)$$

$$N_d(x) = \frac{3G_s(1-\nu^2)}{2tl_x^3} x \cdot m_d + \frac{G_s(1-\nu^2)}{2tl_x} \cdot n_d, \quad (19.2)$$

$$N_l(x) = \frac{3G_s(1-\nu^2)}{2tl_y^3} y \cdot m_L + \frac{G_s(1-\nu^2)}{2tl_y} \cdot n_L, \quad (19.3)$$

$$N_p(x) = \frac{3G_s(1-\nu^2)}{2tl_y^3} y \cdot m_p + \frac{G_s(1-\nu^2)}{2tl_y} \cdot n_p, \quad (19.4)$$

$$T_g(x) = \frac{3G_s(1+\nu)}{2tl_x^3} (l_x^2 - x^2) \cdot t_g, \quad (19.5)$$

$$T_d(x) = \frac{3G_s(1+\nu)}{2tl_x^3} (l_x^2 - x^2) \cdot t_d, \quad (19.6)$$

$$T_l(y) = \frac{3G_s(1+\nu)}{2tl_y^3} (l_y^2 - y^2) \cdot t_L, \quad (19.7)$$

$$T_p(y) = \frac{3G_s(1+\nu)}{2tl_y^3} (l_y^2 - y^2) \cdot t_p \quad (19.8)$$

and

$$n_g = \frac{N_{1g}}{g_1 E_1} - \frac{N_{2g}}{g_2 E_2}, \quad m_g = \frac{M_{1g}}{g_1 E_1} - \frac{M_{2g}}{g_2 E_2}, \quad t_g = \frac{T_{1g}}{g_1 E_1} - \frac{T_{2g}}{g_2 E_2}, \quad (20.1)$$

$$n_d = \frac{N_{1d}}{g_1 E_1} - \frac{N_{2d}}{g_2 E_2}, \quad m_d = \frac{M_{1d}}{g_1 E_1} - \frac{M_{2d}}{g_2 E_2}, \quad t_d = \frac{T_{1d}}{g_1 E_1} - \frac{T_{2d}}{g_2 E_2}, \quad (20.2)$$

$$n_L = \frac{N_{1L}}{g_1 E_1} - \frac{N_{2L}}{g_2 E_2}, \quad m_L = \frac{M_{1L}}{g_1 E_1} - \frac{M_{2L}}{g_2 E_2}, \quad t_L = \frac{T_{1L}}{g_1 E_1} - \frac{T_{2L}}{g_2 E_2}, \quad (20.3)$$

$$n_p = \frac{N_{1p}}{g_1 E_1} - \frac{N_{2p}}{g_2 E_2}, \quad m_p = \frac{M_{1p}}{g_1 E_1} - \frac{M_{2p}}{g_2 E_2}, \quad t_p = \frac{T_{1p}}{g_1 E_1} - \frac{T_{2p}}{g_2 E_2}. \quad (20.4)$$

The structure of the formulae (20.1) - (20.4) yields that there exists an infinite number of sets of edge loading cases for which the functions T_g, N_g, \dots take the same values. Thus, an infinite number of loading sets (not necessarily in equilib-

rium) exists, which lead to the same solutions to the stress equations. Any vector

$$\mathbf{f} = (\mathbf{n}_g, \mathbf{m}_g, \mathbf{t}_g, \mathbf{n}_d, \mathbf{m}_d, \mathbf{t}_d, \mathbf{n}_L, \mathbf{m}_L, \mathbf{t}_L, \mathbf{n}_p, \mathbf{m}_p, \mathbf{t}_p) \in \mathbf{R}^{12}$$

generates the solution of the Eqs. (14.1) - (14.2). This solution is denoted by $(\tau_x, \tau_y)_f$. The vectors

$$\mathbf{e}_1 = (1, 0, 0, 0, 0, 0, 0, 0, 0, 0, 0, 0),$$

$$\mathbf{e}_2 = (0, 1, 0, 0, 0, 0, 0, 0, 0, 0, 0, 0),$$

...

$$\mathbf{e}_{12} = (0, 0, 0, 0, 0, 0, 0, 0, 0, 0, 0, 1)$$

form the base of the linear space \mathbf{R}^{12} . It is easy to verify that the set of all solutions $(\tau_x, \tau_y)_f$, $\mathbf{f} \in \mathbf{R}^{12}$, is a linear space with the base $(\tau_x, \tau_y)_{\mathbf{e}_i}$, $i = 1, 2, \dots, 12$. Then for an arbitrary vector

$$\mathbf{f} = (\mathbf{n}_g, \mathbf{m}_g, \mathbf{t}_g, \mathbf{n}_d, \mathbf{m}_d, \mathbf{t}_d, \mathbf{n}_L, \mathbf{m}_L, \mathbf{t}_L, \mathbf{n}_p, \mathbf{m}_p, \mathbf{t}_p) \in \mathbf{R}^{12}$$

the solution $(\tau_x, \tau_y)_f$ of the boundary value problem (14.1) - (14.2), (15) - (18) can be given by the formula

$$\begin{aligned} (\tau_x, \tau_y)_f = & \mathbf{n}_g \cdot (\tau_x, \tau_y)_{\mathbf{e}_1} + \mathbf{m}_g \cdot (\tau_x, \tau_y)_{\mathbf{e}_2} + \mathbf{t}_g \cdot (\tau_x, \tau_y)_{\mathbf{e}_3} + \mathbf{n}_d \cdot (\tau_x, \tau_y)_{\mathbf{e}_4} + \\ & + \mathbf{m}_d \cdot (\tau_x, \tau_y)_{\mathbf{e}_5} + \mathbf{t}_d \cdot (\tau_x, \tau_y)_{\mathbf{e}_6} + \mathbf{n}_L \cdot (\tau_x, \tau_y)_{\mathbf{e}_7} + \mathbf{m}_L \cdot (\tau_x, \tau_y)_{\mathbf{e}_8} + \\ & + \mathbf{t}_L \cdot (\tau_x, \tau_y)_{\mathbf{e}_9} + \mathbf{n}_p \cdot (\tau_x, \tau_y)_{\mathbf{e}_{10}} + \mathbf{m}_p \cdot (\tau_x, \tau_y)_{\mathbf{e}_{11}} + \mathbf{t}_p \cdot (\tau_x, \tau_y)_{\mathbf{e}_{12}}. \end{aligned} \quad (21)$$

The base functions are obtained by 12-fold solving of the boundary value problem (14.1) - (14.2), (15) - (18) for the loading cases defined by the vectors $\mathbf{e}_1, \dots, \mathbf{e}_{12}$. The functions $(\tau_x, \tau_y)_{\mathbf{e}_i}$ for $i = 1, 2, \dots, 12$ are shown in Figs. 4–15.

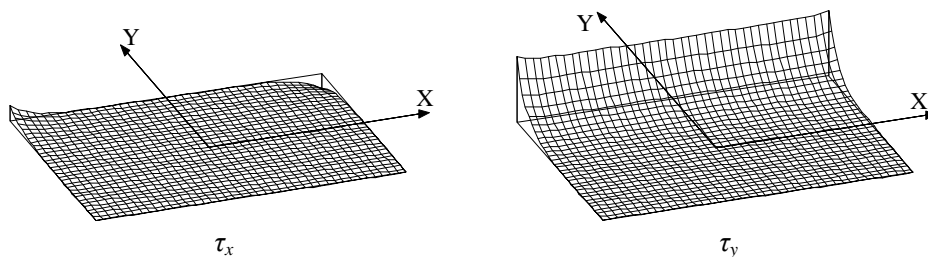
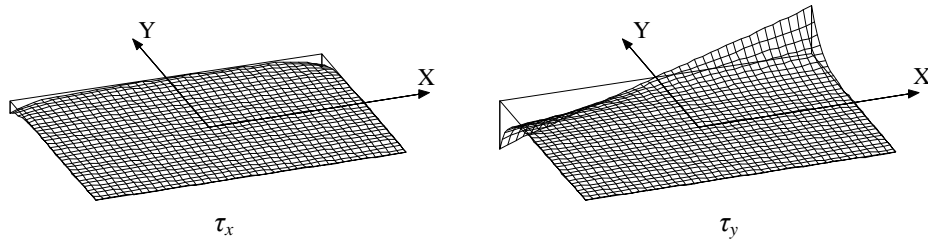
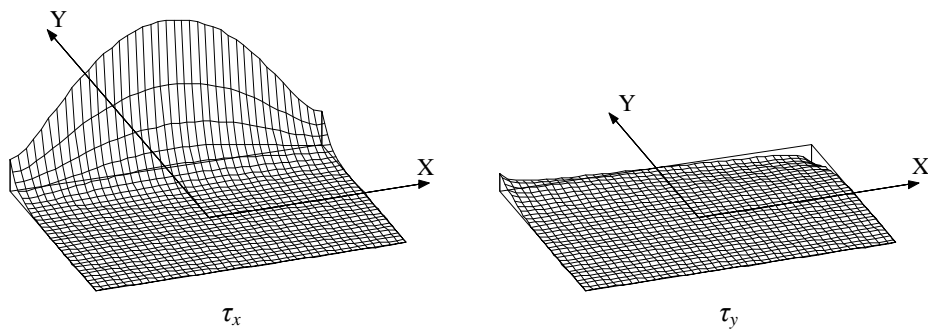
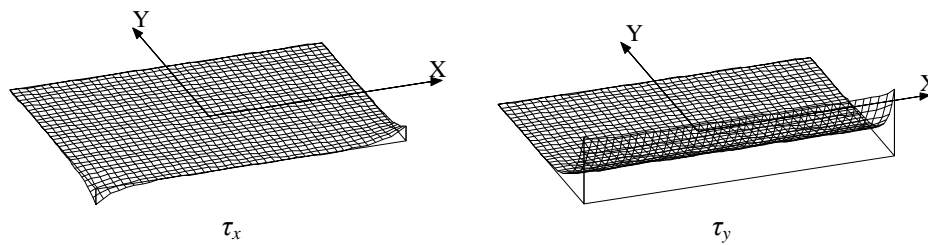
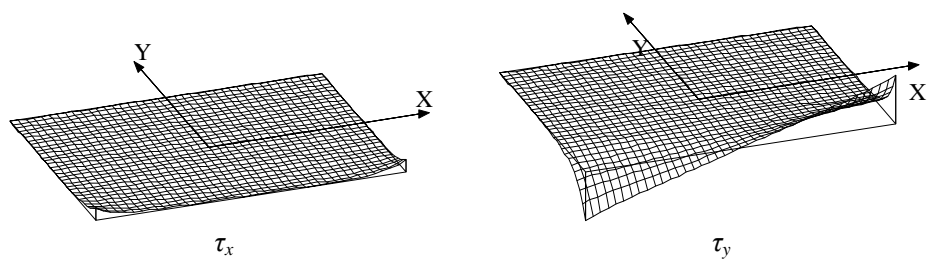

Fig. 4. The base function $(\tau_x, \tau_y)_{\mathbf{e}_1}$

Fig. 5. The base function $(\tau_x, \tau_y)_e2$ Fig. 6. The base function $(\tau_x, \tau_y)_e3$ Fig. 7. The base function $(\tau_x, \tau_y)_e4$ Fig. 8. The base function $(\tau_x, \tau_y)_e5$

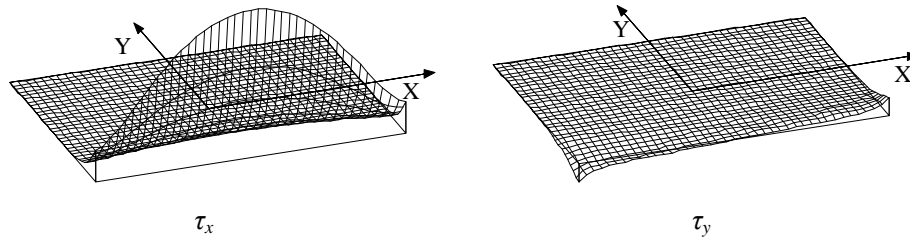

Fig. 9. The base function $(\tau_x, \tau_y)_{e6}$

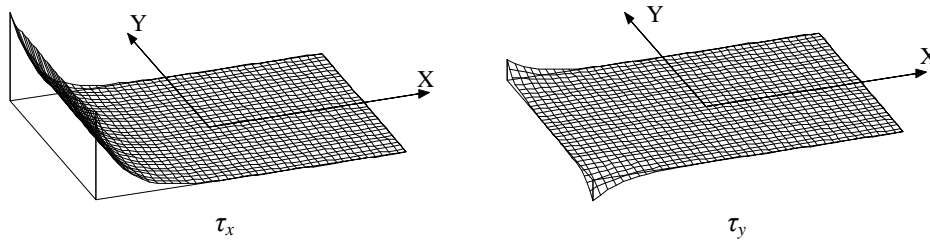

Fig. 10. The base function $(\tau_x, \tau_y)_{e7}$

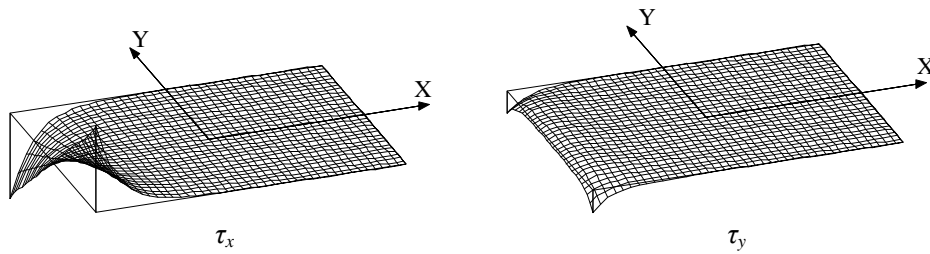

Fig. 11. The base function $(\tau_x, \tau_y)_{e8}$

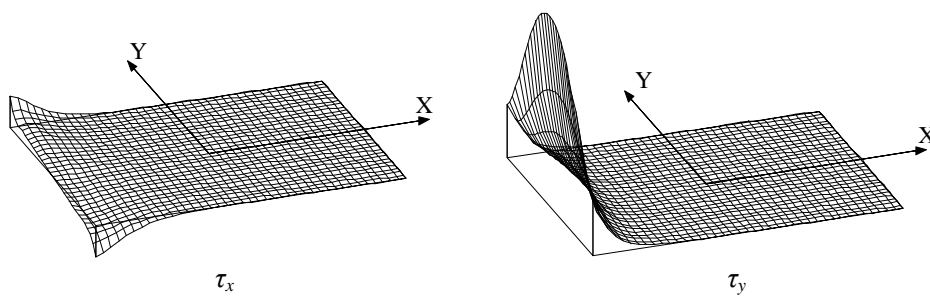
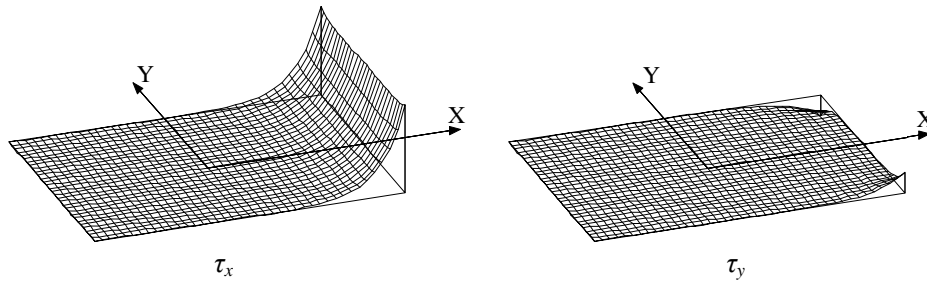
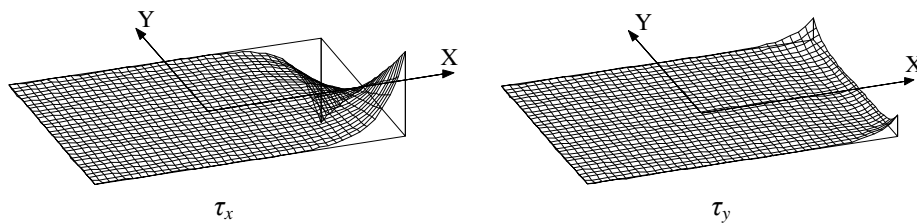
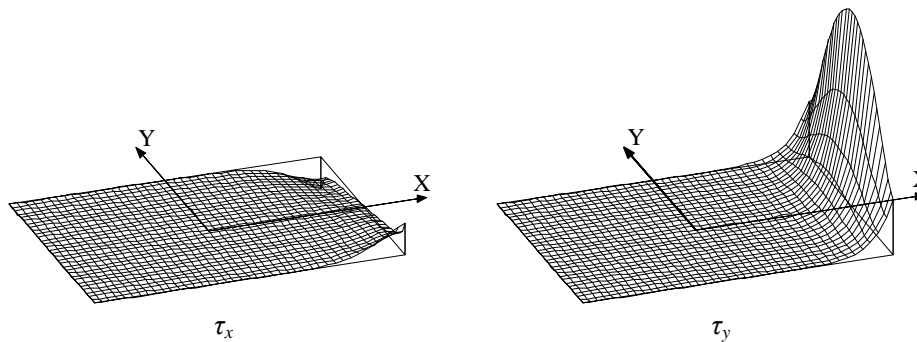

Fig. 12. The base function $(\tau_x, \tau_y)_{e9}$

Fig. 13. The base function $(\tau_x, \tau_y)_{e10}$ Fig. 14. The base function $(\tau_x, \tau_y)_{e11}$ Fig. 15. The base function $(\tau_x, \tau_y)_{e12}$

Let us consider an adhesive joint between two steel adherends with the dimensions: $l_x = 5.0$ cm, $l_y = 4.0$ cm. The adherend thicknesses are $g_1 = g_2 = 0.4$ cm and the adhesive thickness is $t = 0.04$ cm. The material constants are: $E_1 = E_2 = 2.05 \times 10^7$ N/cm², $\nu_1 = \nu_2 = 0.281$, $G_s = 4.5 \times 10^5$ N/cm². The adherends are subjected to the loading: $N_{1d} = 4.0$ N, $M_{1L} = -12.0$ N·cm, $N_{1p} = 8.0$ N, $T_{2g} = -8.0$ N, $T_{2p} = -4.0$ N. The edge stress due to these loading cases are presented in Fig.

16. For the loading vector $f = (0, 0, t_g, n_d, 0, 0, 0, 0, m_L, 0, n_p, 0, t_p)$ from the formulae (20.1) - (20.4) one gets

$$t_g = 9.7561 \times 10^{-7} \text{ cm}, n_d = 4.8780 \times 10^{-7} \text{ cm}, m_L = -14.6341 \times 10^{-7} \text{ cm}^2,$$

$$n_p = 9.7561 \times 10^{-7} \text{ cm}, t_p = 4.8780 \times 10^{-7} \text{ cm}.$$

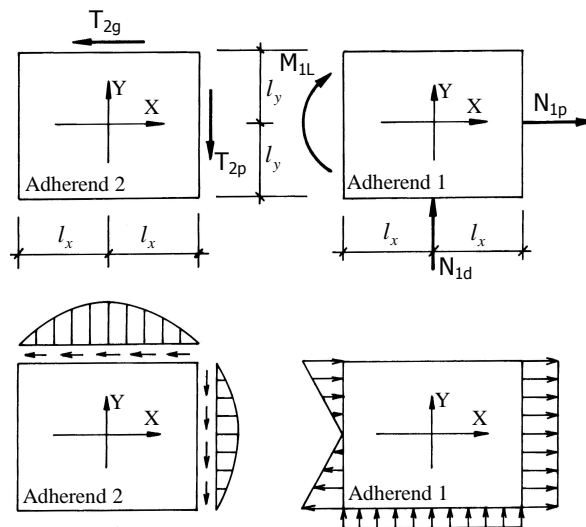
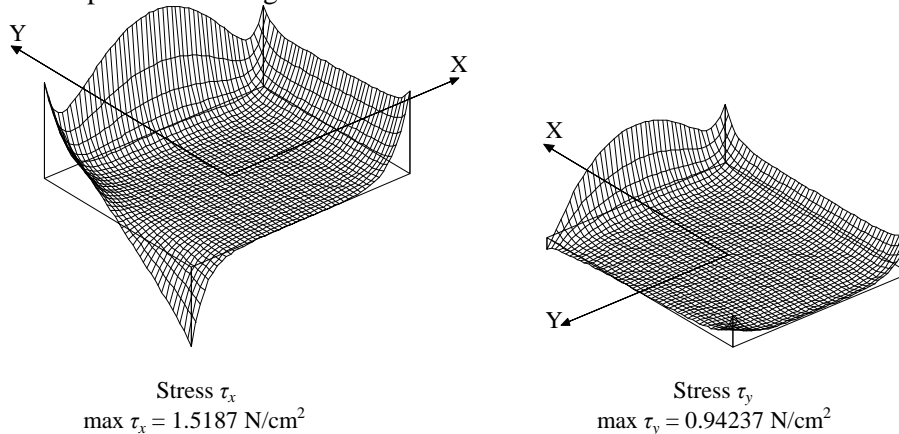

Fig. 16. Adhesive joint subjected to a complex loadin

According to (21) the solution is given by

$$(\tau_x, \tau_y)_f = t_g \cdot (\tau_x, \tau_y)_{e3} + n_d \cdot (\tau_x, \tau_y)_{e4} + m_L \cdot (\tau_x, \tau_y)_{e8} + n_p \cdot (\tau_x, \tau_y)_{e10} + t_p \cdot (\tau_x, \tau_y)_{e12}$$

and is presented in Fig. 17.



Stress τ_x

$$\max \tau_x = 1.5187 \text{ N/cm}^2$$

Stress τ_y

$$\max \tau_y = 0.94237 \text{ N/cm}^2$$

Fig. 17. Stresses in adhesive of a joint under a complex loading

9. FINAL REMARKS

Solutions of the Eqs. (14.1) - (14.2) for the shear stress in the adhesive possess interesting algebraic properties. One can conclude from the formulae (20.1) - (20.4), that there exists an infinite number of boundary loading layouts in a form of normal forces, moments and shear forces (not necessarily in equilibrium) which lead to the same solution of the boundary value problem (14.1) - (14.2), (15) - (18). In the set of loadings an equivalence relation can be introduced, which identifies loading types leading to the same solution of the boundary value problem. Therefore, the loading set can be subdivided into disjoint equivalence classes. One equivalence class consists of all equivalent loading types, i.e. the ones leading to the same solution. In the set of equivalence classes a linear space structure can be introduced and called the loading space. Then a linear isomorphism of the loading space and the space of solutions for the boundary value problem (14.1) - (14.2), (15) - (18) can be constructed. For the boundary loading types consisting of normal forces, moments and shear forces the loading space and the solution space are 12-dimensional. Hence, there exists a base consisting of 12 base functions in the solution space, which generate all solutions of the boundary value problem (14.1) - (14.2), (15) - (18).

Solutions for stresses in the adhesive are uniquely defined by static boundary conditions.

It is also worth noting the influence of the Poisson's ratio ν on properties of solutions for such plane stress elements like adhesive joints. The role of the coefficient ν is emphasized when analyzing problems formulated for single plane stress elements, where the cases without the Poisson's ratio are distinguished. For instance, the stress state in a single element with a constant thickness loaded on edges only or under a constant self weight does not depend on the Poisson's ratio. Generally, when a loading is applied on the element surface only or when the boundary conditions concern displacements, then the solution depends on the Poisson's ratio [4, 5, 15]. This is the case of the adhesive joints analyzed in the present paper, because an adherend can be viewed as a plane stress element loaded on its surface by stresses from an adhesive.

REFERENCES

1. Adams R.D., Peppiatt N.A.: *Effect of Poisson's ratio strains in adherends on stresses of an idealized lap joint*. Journal of Strain Analysis Vol. 8. No 2 (1974), pp. 134 - 139.
2. Adams R.D., Wake W.C.: *Structural Adhesive Joints in Engineering*. Elsevier Appl. Sci. Publ. Ltd. 1986.

3. Ficarra Ch.H.: *Analysis of adhesive bonded fiber-reinforced composite joints*. Dissertation, North Carolina State University 2001. *Adhesion & Adhesives* 29 (2009) 331-341.
4. Fung Y.C.: *Foundations of solid mechanics*. Prentice-Hall, Inc., Englewood Cliffs, New Jersey, U.S.A. 1965.
5. Girkmann K.: *Flächentragwerke*. Springer-Verlag, Wien 1956.
6. Kim H., Kedward K.: *Stress Analysis of In-Plane, Shear-Loaded, Adhesively Bonded Composite Joints and Assemblies*. U.S. Department of Transportation Federal Aviation Administration, Office of Aviation Research Washington, D.C. 20591, Final Report DOT/FAA/AR-01/7, 2001.
7. Kim H., Kedward K.: *Stress Analysis of Adhesive Bonded Joints Under In-Plane Shear Loading*. *Journal of Adhesion*, 76 (2001), No 1, pp. 1 - 36.
8. Mathias J.D., Grédiac M., Balandraud X.: *On the bi-directional stress distribution in rectangular bonded composite patches*. *International Journal of Solids and Structures* 43 (2006) pp. 6921 - 6947.
9. Mathias J.D., Grédiac M.: *Applying the grid method to validate a numerical model predicting the transverse shear stress distributions in patched structures*. *Composites: Part A* 39 (2008) pp. 1194 - 1209.
10. Rapp P.: *Mechanika połączeń klejowych jako płaskie zadanie teorii sprężystości*. Wydawnictwo Politechniki Poznańskiej, Rozprawy Nr 441, Poznan 2010.
11. Rapp P.: *Mechanics of adhesive joints as a plane problem of the theory of elasticity. Part I: General formulation*. *Archives of Civil and Mechanical Engineering*, Vol. X, No.2 (2010) pp. 81 - 108.
12. Rapp P.: *Mechanics of adhesive joints as a plane problem of the theory of elasticity. Part II: Displacement formulation for orthotropic adherends*. *Archives of Civil and Mechanical Engineering*, Vol. , No. , 2014
13. Silva L.F.M., Neves P.J.C., Adams R.D., Spelt J.K.: *Analytical models of adhesively bonded joints - Part I: Literature survey*. *International Journal of Adhesion & Adhesives* 29 (2009) pp. 319-330.
14. Silva L.F.M., Neves P.J.C., Adams R.D., Wang A., Spelt J.K.: *Analytical models of adhesively bonded joints - Part II: Comparative study*. *International Journal of Adhesion & Adhesives* 29 (2009) pp. 331-341.
15. Timoshenko S., Goodier J. N.: *Theory of elasticity*. McGraw-Hill Book Company, Inc., New York, Toronto, London, 1951.
16. Volkersen O.: *Die Nietkraftverteilung von zugbeanspruchten Nietverbindungen mit konstante Laschenquerschnitten*. *Luftfahrtforschung* 15, 1-2(1938), pp. 41- 47.

RÓWNANIA NAPRĘŻEŃ W PŁASKICH DWUWYMIAROWYCH SPOINACH KLEJOWYCH

Streszczenie

Przedmiotem pracy jest sformułowanie równań dla naprężeń stycznych w płaskich dwuwymiarowych spoinach występujących w połączeniach klejowych. Elementy połączenia mają stałe grubości i są wykonane materiałów izotropowych. Kształt elementów w płaszczyźnie połączenia może być dowolny. Połączenia klejowe mogą być obciążone naprężeniami stycznymi dowolnie rozłożonymi na powierzchniach elementów oraz naprężeniami normalnymi i stycznymi dowolnie rozłożonymi na krawędziach elementów. Sformułowano układ dwóch równań różniczkowych cząstkowych rzędu drugiego, w których niewiadomymi są naprężenia styczne w spoinie. Dla połączeń prostokątnych zbudowano zbiór 12 funkcji bazowych, których odpowiednia kombinacja liniowa jednoznacznie określa naprężenia styczne w spoinie połączenia klejowego obciążonego dowolnym układem sił normalnych, momentów zginających i sił poprzecznych

Słowa kluczowe: połączenie klejowe, modele analityczne, dwuwymiarowa analiza naprężeń w spoinie klejowej, izotropia, sprężystość liniowa

Editor received the manuscript: 27.09.2014